

Features and Benefits

- Chopper stabilized amplifier stage
- Micropower consumption for battery-powered applications
- Omnipolar, output switches with absolute value of North or South pole from magnet
- Operation down to 2.5V
- High Sensitivity for direct reed switch replacement applications

Applications

- Solid state switch
- Handheld Wireless Handset Awake Switch
- Lid close sensor for battery powered devices
- Magnet proximity sensor for reed switch replacement in low duty cycle applications

Ordering Information

Part No.	Temperature Code	Package Code
MLX90248	E (-40 to 85°C)	SO (SOT-23)

Functional Diagram

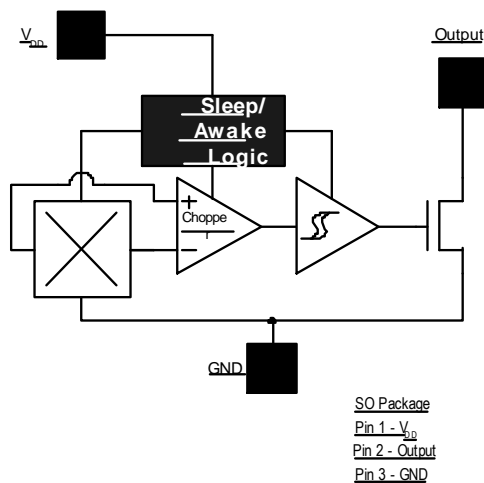

Note: Static sensitive device; please observe ESD precautions. Reverse V_{DD} protection is not included. For reverse voltage protection, a 100Ω resistor in series with V_{DD} is recommended.

Description

The MLX90248 Omnipolar™ Hall effect sensor IC is fabricated from mixed signal CMOS technology. It incorporates advanced chopper-stabilization techniques to provide accurate and stable magnetic switch points.

The circuit design provides an internally controlled clocking mechanism to cycle power to the Hall element and analog signal processing circuits. This serves to place the high current-consuming portions of the circuit into a “Sleep” mode. Periodically the device is “Awakened” by this internal logic and the magnetic flux from the Hall element is evaluated against the predefined thresholds. If the flux density is above or below the B_{OP}/B_{RP} thresholds then the output transistor is driven to change states accordingly. While in the “Sleep” cycle the output transistor is latched in its previous state. The design has been optimized for service in applications requiring extended operating lifetime in battery powered systems.

The output transistor of the 90248 will be latched on (B_{OP}) in the presence of a sufficiently strong South or North magnetic field facing the marked side of the package. The output will be latched off (B_{RP}) in the absence of a magnetic field.

MLX90248 Electrical Specifications

DC operating parameters: $T_A = 25^\circ\text{C}$, $V_{DD} = 3V_{DC}$ (unless otherwise specified).

<i>Parameter</i>	<i>Symbol</i>	<i>Test Conditions</i>	<i>Min</i>	<i>Typ</i>	<i>Max</i>	<i>Units</i>
Supply Voltage	V_{DD}	Operating	2.5	2.75	3.5	V
Supply Current	I_{DD}	Average		10		μA
Output Current	I_{out}				1	mA
Saturation Voltage	V_{SAT}	$I_{OUT}=1\text{mA}$			0.4	V
Awake mode time	T_{aw}	Operating		150		μS
Sleep mode time	T_{sl}	Operating		50	70	mS

Magnetic Specifications

DC operating parameters: $T_A = 25^\circ\text{C}$, $V_{DD} = 3 V_{DC}$ (unless otherwise specified).

90248

<i>Parameter</i>	<i>Symbol</i>	<i>Test Conditions</i>	<i>Min</i>	<i>Typ</i>	<i>Max</i>	<i>Units</i>
Operating Point	B_{OP}			+/-3.8	+/-6.0	mT
Release Point	B_{RP}		+/-0.5	+/-2.1		mT
Hysteresis	B_{hys}			1.7		mT

Note: 1 $\text{mT} = 10$ Gauss.

Absolute Maximum Ratings

Supply Voltage (Operating), V_{DD}	5V
Supply Current (Fault), I_{DD}	5mA
Output Voltage, V_{OUT}	5V
Output Current (Fault), I_{OUT}	5mA
Operating Temperature Range, T_A	-40 to 85°C
Storage Temperature Range, T_S	-55 to 150°C

Melexis Inc. reserves the right to make changes without further notice to any products herein to improve reliability, function or design. Melexis does not assume any liability arising from the use of any product or application of any product or circuit described herein.

Performance Graphs

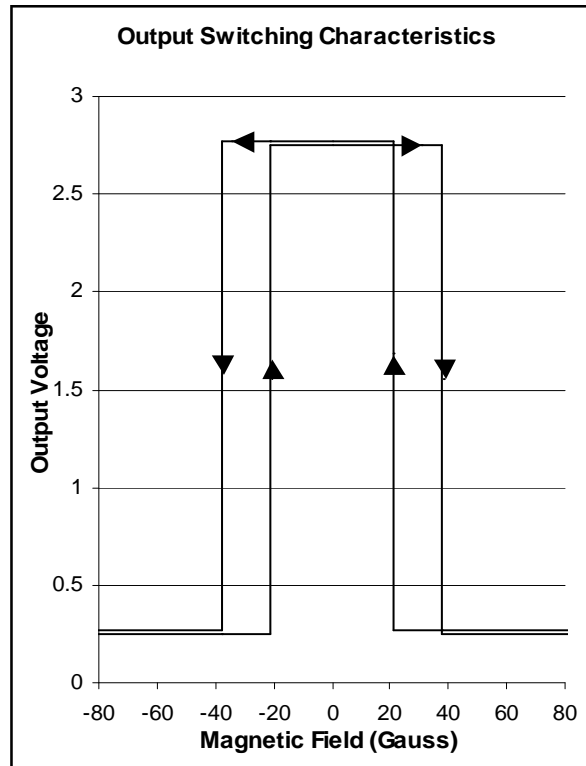
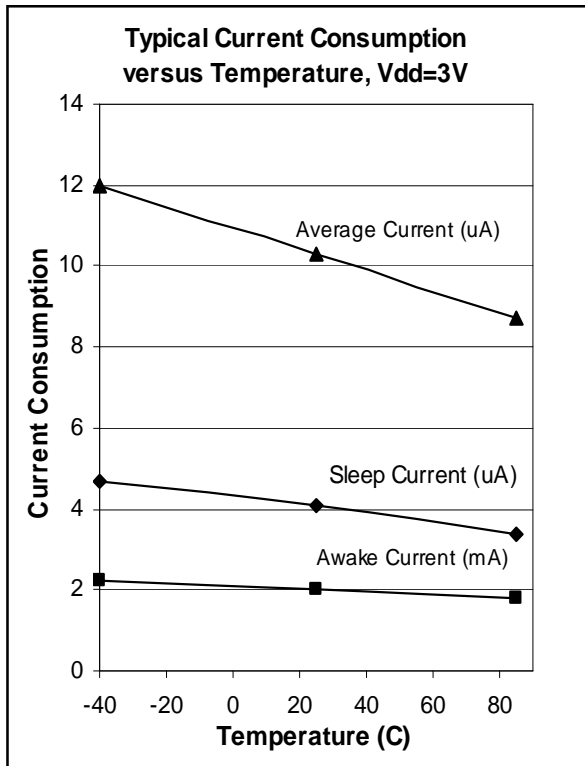
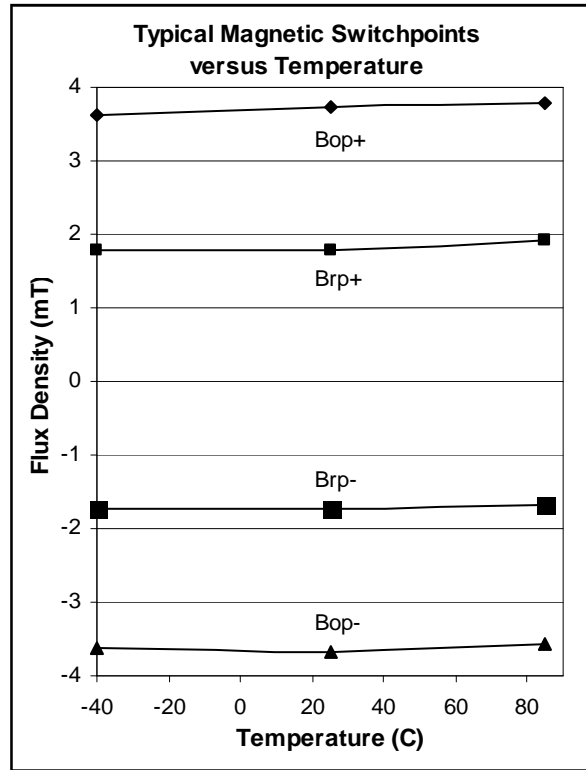
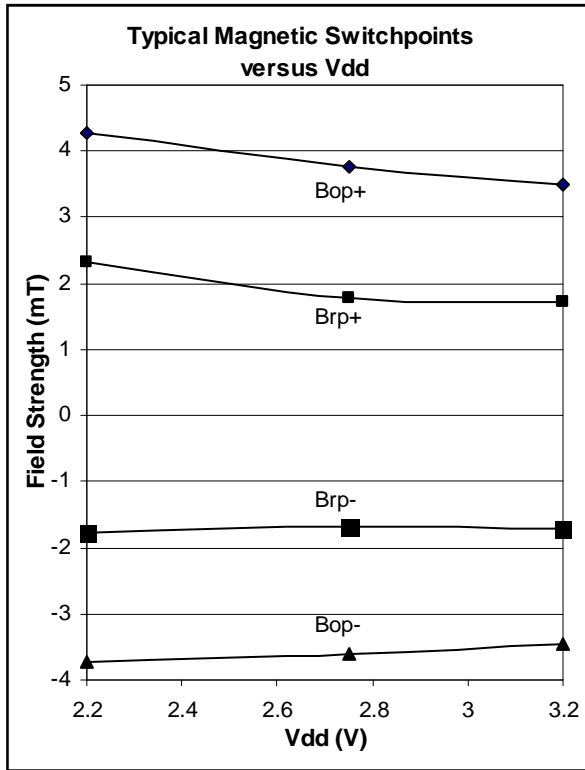

Unique Features

CMOS Hall IC Technology

The chopper stabilized amplifier uses switched capacitor techniques to eliminate the amplifier offset voltage, which, in bipolar devices, is a major source of temperature sensitive drift.

CMOS makes this advanced technique possible. The CMOS chip is also much smaller than a bipolar chip, allowing very sophisticated circuitry to be placed in less space. The small chip size also contributes to lower physical stress and less power consumption.

Installation Comments

Consider temperature coefficients of Hall IC and magnetics, as well as air gap and life time variations. Observe temperature limits during wave soldering.

Typical Application

SOT-23 (Top View)

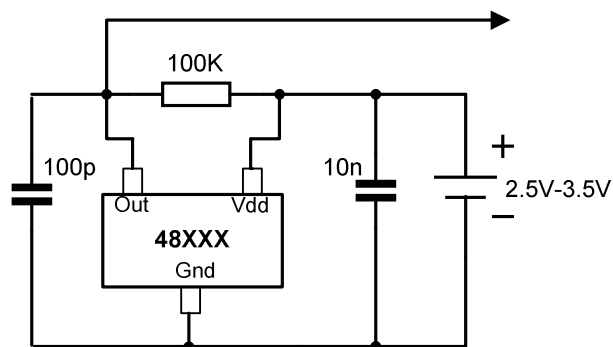

SOT-23 Package Physical Characteristics

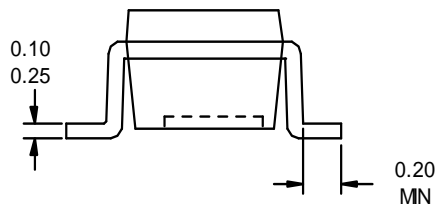
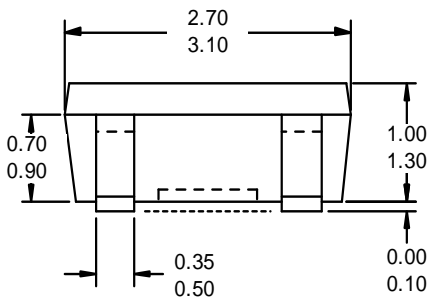
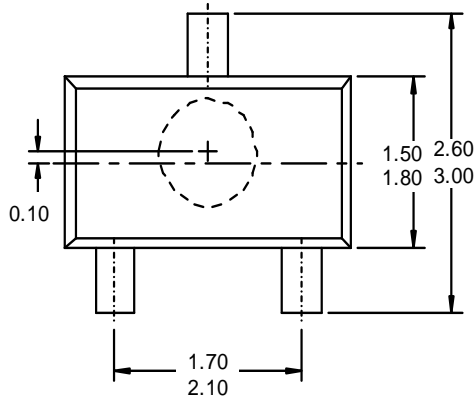

SOT-23 Package Hall Location

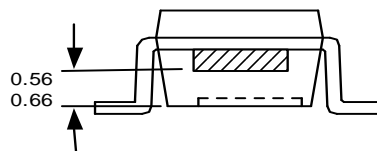
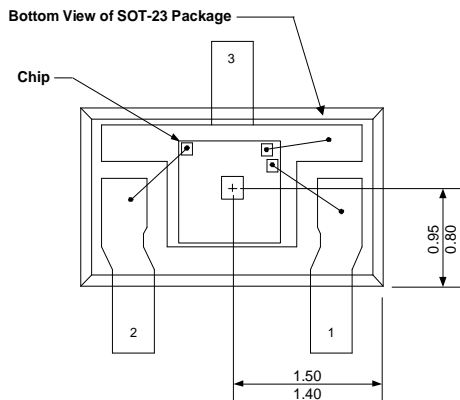

Reliability Information

This Melexis device is classified and qualified regarding soldering technology, solderability and moisture sensitivity level, as defined in this specification, according to following test methods:

- IPC/JEDEC J-STD-020
Moisture/Reflow Sensitivity Classification For Nonhermetic Solid State Surface Mount Devices (classification reflow profiles according to table 5-2)
- EIA/JEDEC JESD22-A113
Preconditioning of Nonhermetic Surface Mount Devices Prior to Reliability Testing (reflow profiles according to table 2)
- CECC00802
Standard Method For The Specification of Surface Mounting Components (SMDs) of Assessed Quality
- EIA/JEDEC JESD22-B106
Resistance to soldering temperature for through-hole mounted devices
- EN60749-15
Resistance to soldering temperature for through-hole mounted devices
- MIL 883 Method 2003 / EIA/JEDEC JESD22-B102
Solderability

For all soldering technologies deviating from above mentioned standard conditions (regarding peak temperature, temperature gradient, temperature profile etc) additional classification and qualification tests have to be agreed upon with Melexis.

The application of Wave Soldering for SMD's is allowed only after consulting Melexis regarding assurance of adhesive strength between device and board.

Based on Melexis commitment to environmental responsibility, European legislation (Directive on the Restriction of the Use of Certain Hazardous substances, RoHS) and customer requests, Melexis has installed a Roadmap to qualify their package families for lead free processes also.

Various lead free generic qualifications are running, current results on request.

For more information on manufacturability/solderability see quality page at our website:

<http://www.melexis.com/html/pdf/MLXleadfree-statement.pdf>

ESD Precautions

Electronic semiconductor products are sensitive to Electro Static Discharge (ESD).

Always observe Electro Static Discharge control procedures whenever handling semiconductor products.

Disclaimer

Devices sold by Melexis are covered by the warranty and patent indemnification provisions appearing in its Term of Sale. Melexis makes no warranty, express, statutory, implied, or by description regarding the information set forth herein or regarding the freedom of the described devices from patent infringement. Melexis reserves the right to change specifications and prices at any time and without notice. Therefore, prior to designing this product into a system, it is necessary to check with Melexis for current information. This product is intended for use in normal commercial applications. Applications requiring extended temperature range, unusual environmental requirements, or high reliability applications, such as military, medical life-support or life-sustaining equipment are specifically not recommended without additional processing by Melexis for each application.

The information furnished by Melexis is believed to be correct and accurate. However, Melexis shall not be liable to recipient or any third party for any damages, including but not limited to personal injury, property damage, loss of profits, loss of use, interrupt of business or indirect, special incidental or consequential damages, of any kind, in connection with or arising out of the furnishing, performance or use of the technical data herein. No obligation or liability to recipient or any third party shall arise or flow out of Melexis' rendering of technical or other services.

© 2002 Melexis NV. All rights reserved.

For the latest version of this document. Go to our website at
www.melexis.com

Or for additional information contact Melexis Direct:

Europe and Japan:

Phone: +32 1367 0495

E-mail: sales_europe@melexis.com

All other locations:

Phone: +1 603 223 2362

E-mail: sales_usa@melexis.com

ISO/TS 16949 and ISO14001 Certified