

## CSA-1V

### Current Sensor



#### Features:

- Sensitive to a magnetic field parallel to the chip surface
- Very high sensitivity
- Linear output voltage proportional to a magnetic field
- Wide-band: DC to 100kHz
- Very low offset and offset-drift
- Very low noise
- Isolated from current conductor
- Surface mount SOIC-8 package

#### Applications:

- AC and/or DC current measurement
- Wide-Band Magnetic Field Measurement
- Battery Chargers
- AC-DC Converters
- Motor Control

#### General Description

The CSA-1V is a single-axis integrated magnetic field sensor based on the Hall effect. It produces a linear, ratio-metric output voltage proportional to the applied magnetic field parallel with the chip surface. The circuit is fabricated using a standard CMOS process. The additional ferromagnetic layer that is added in a simple post-processing step, amplifies the magnetic field and concentrates it on the Hall elements. Therefore the circuit features very high magnetic sensitivity, low offset, and low noise. The CSA-1V is packaged in a standard SOIC-8 full plastic package and suitable for up to 600V isolation voltage between the sensor and a conductor on PCB.

Please find the latest version of this datasheet and related information such as application notes on our website [www.sentron.ch](http://www.sentron.ch)

**Package:** SOIC-8

#### Pin Out:

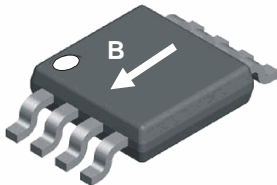

- 1 A\_OUT, analog sensor output
- 2 V<sub>DD</sub> pos. supply voltage
- 3 Not connected
- 4 PV, programming voltage <sup>1)</sup>
- 5 GND, supply common
- 6 PD, programming data <sup>1)</sup>
- 7 PC, programming clock <sup>1)</sup>
- 8 CO\_OUT, common output

Note 1: Used for factory programming

### Absolute Maximum Ratings

Symbol	Parameter	Min.	Typ.	Max.	Unit	Remarks
V <sub>SUP</sub>	Supply Voltage	0		6	V	
T	Ambient Temperature	-40		+125	°C	

### Recommended Operating Conditions

Symbol	Parameter	Min.	Typ.	Max.	Unit	Remarks
V <sub>SUP</sub>	Supply Voltage	4.5	5	5.5	V	
I <sub>OUT</sub>	Output Current	-1		1	mA	
C <sub>L</sub>	Load Capacitance			1000	pF	Defined by design

### Electrical Characteristics

At T=-40°C to 125°C, V<sub>SUP</sub>=4.5V to 5.5V if not otherwise specified.

Symbol	Parameter	Min.	Typ.	Max.	Unit	Test Conditions
I <sub>SUP</sub>	Supply Current		11	16	mA	
V <sub>Common</sub>	Common (reference) Output Voltage <sup>2)</sup>	-50	V <sub>SUP</sub> /2	+50		I <sub>OUT</sub> =0mA
BW	Bandwidth: DC to		100		kHz	
t <sub>R</sub>	Response Time		8		µs	

Note 2: Ratiometric (proportional to V<sub>SUP</sub>)

### Characteristics of the Linear Magnetic Field Sensor<sup>3,4)</sup>

With V<sub>SUP</sub>= 5V and in the temperature range -40°C to 125°C, if not otherwise specified.

Symbol	Parameter	Min.	Typ.	Max.	Unit	Test Conditions
S	Magnetic Sensitivity at 25 °C <sup>3) 6)</sup>	275	280	285	V/T	B = B <sub>L</sub>
ΔS/ΔT	Magn. Sensitivity Temperature Drift		<± 0.02		%/°C	I <sub>OUT</sub> =0mA T=-20°C to 125°C
V <sub>off</sub>	Offset Voltage at 25 °C	-20	0	20	mV	B=0T, I <sub>OUT</sub> =0mA, T=20°C
ΔV <sub>off</sub> /ΔT	Offset Temperature Drift		<± 0.2		mV/°C	B=0T, I <sub>OUT</sub> =0mA, T=-20°C to 125°C
B <sub>FS</sub>	Full Scale Magnetic Field Range <sup>5)</sup>	-10		10	mT	
B <sub>L</sub>	Linear Magnetic Field Range	-7.5		7.5	mT	
NL	Non Linearity		±0.2		%	B = B <sub>L</sub>
			±0.5			B = B <sub>FS</sub>
ΔB <sub>noise</sub>	Input referred magnetic noise spectrum density (RMS)		<125		nT/√Hz	f=10Hz to 10kHz

Note 3: Ratiometric (proportional to V<sub>SUP</sub>)

Note 4: When the analog output pin A\_OUT is used in differential mode (i.e. V<sub>out</sub> = A\_OUT-CO\_OUT)

Note 5: Device saturates for B>B<sub>FS</sub>, but is not damaged

Note 6: The absolute accuracy on magnetic sensitivity trimming is +/- 2%

Sentron AG reserves the right to make changes without further notice to any products herein to improve reliability, function, or design. Sentron does not assume any liability arising from the use of any product or application of any product or circuit described herein.

**Block Diagram**

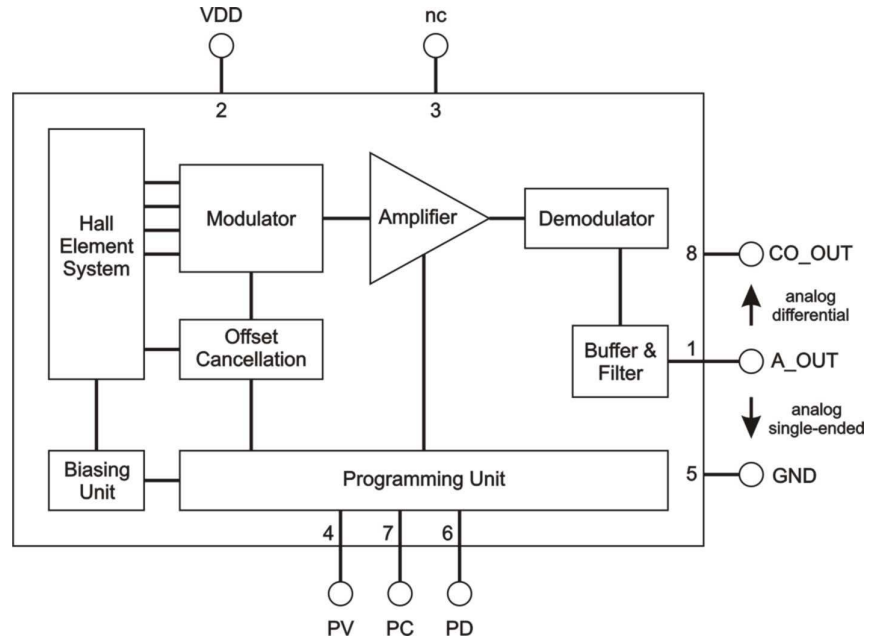
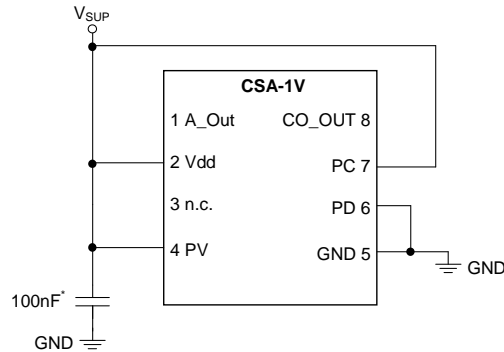

Fig. 1 Block diagram of CSA-1V

**IMPORTANT**

For reliable operation within the specifications the sensor must be connected as follows:

- Connect Pin 6 (PD) to Pin 5 (GND)
- Connect Pin 7 (PC) to Pin 2 (Vdd)
- Connect Pin 4 (PV) to Pin 2 (Vdd)
- Put a 100nF capacitor close to the chip between Pin 2 (Vdd) and Pin 5 (GND)



\* If the supply voltage is disturbed by EMI it can be useful to place a second capacitor (100pF, ceramic) parallel to the 100nF capacitor.

Fig. 2 Connection diagram of CSA-1V

**Package Information SOIC-8**

**B: Magnetic sensitive direction**

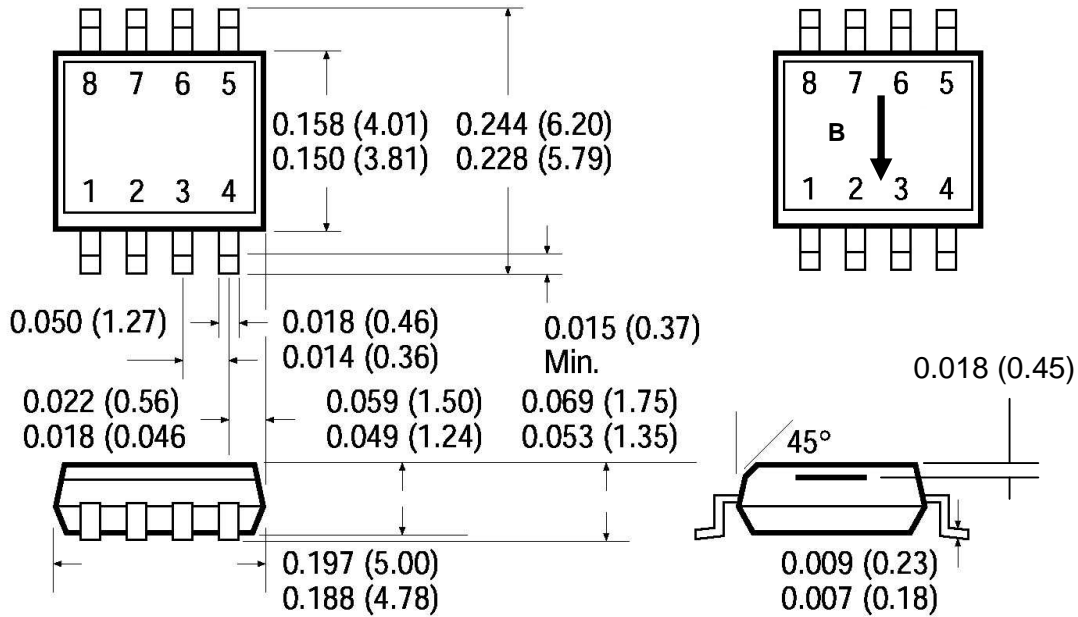

Fig. 3 Package information and magnetic sensitive direction

**Package versions**

Leaded (standard): CSA-1V

Material: C151, 85/15

Lead free 'green': CSA-1V-G

Material: CDA151, Pb <100ppm

## Typical Applications

### Busbar Current Measurement

The current conductor is situated above the chip.

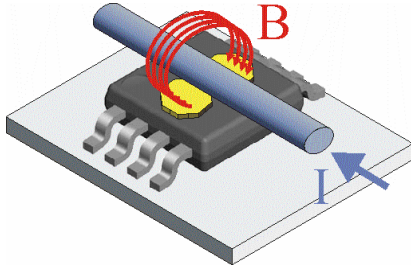

A current conductor is placed at a certain distance above or beyond the chip. The magnetic field around a long current wire is described by  $H=I/2\pi r$ . The flux density at the place of the sensor depends upon the current in the wire  $I$  and the distance between sensor and wire  $r$ :  
 $B= \mu_0 * I / 2 \pi r$ .

All examples for  $S=280V/T$

Max current [A]	Distance sensor to wire [mm]	Sensitivity [mV/A]	Approx. Resolution (raw) [A]	Approx. Resolution ( $t_{INT}=1ms$ ) [A]	Typ. Linearity Error [%]
10	0.2	120	0.1	0.01	<0.2
50	2	25	0.5	0.05	
100	4	12	1	0.1	
500	20	3	3.5	0.35	
1000	40	1.5	7	0.7	

### PCB Current Measurement

The current conductor is situated below the chip (on PCB).



The CSA-1V current sensor is placed on a PCB directly over the current track. The current track can consist of one or several loops, depending on the maximum current to be measured. The sensor measures the magnetic field emanating from the current flowing through the tracks.

Typically obtained values for for this type of application are (width of PCB current track 2.5mm):

Max current(*) [A] DC / pulsed	No of tracks under sensor	Sensitivity [mV/A]	Resolution (raw) [mA]	Resolution $t_{INT}=1ms$ [mA]	Typ. Linearity Error [%]
2 / 10	4	140	70	7	<0.2
10 / 50	1	35	280	28	

(\*) max current depends on PCB properties/thermal budget

Please contact us for documentation such as application notes, technical papers and others.

This document is published by:  
**Sentron AG, a Melexis Company**

For Technical and Commercial Support:

For North America: [www.gmw.com](http://www.gmw.com), [sales@gmw.com](mailto:sales@gmw.com)

For the rest of the world: [www.melexis.com](http://www.melexis.com), [sales\\_europe@melexis.com](mailto:sales_europe@melexis.com)

Application notes are available on the website.

#### IMPORTANT NOTICE / DISCLAIMER

Devices sold by Sentron are covered by the warranty and patent indemnification provisions appearing in its Term of Sale. Sentron makes no warranty, express, statutory, implied, or by description regarding the information set forth herein or regarding the freedom of the described devices from patent infringement. Sentron reserves the right to change specifications and prices at any time and without notice. Therefore, prior to designing this product into a system, it is necessary to check with Sentron for current information. This product is intended for use in normal commercial applications.

Applications requiring extended temperature range, unusual environmental requirements, or high reliability applications, such as military, medical life-support or life-sustaining equipment are specifically not recommended without additional processing by Sentron for each application.

The information furnished by Sentron is believed to be correct and accurate. However, Sentron shall not be liable to recipient or any third party for any damages, including but not limited to personal injury, property damage, loss of profits, loss of use, interrupt of business or indirect, special incidental or consequential damages, of any kind, in connection with or arising out of the furnishing, performance or use of the technical data herein. No obligation or liability to recipient or any third party shall arise or flow out of Sentron's rendering of technical or other services.

© 2005 Sentron AG. All rights reserved.