

## Scope

This datasheet describes the schematic, the layout and the use of the series of small breakout boards for MLX90609 angular rate sensor. It is fully applicable to EVB90609-N2, EVB90609-E2 and EVB90609-R2 boards and can be used as reference for populating the EVB90609 board.

## General Description

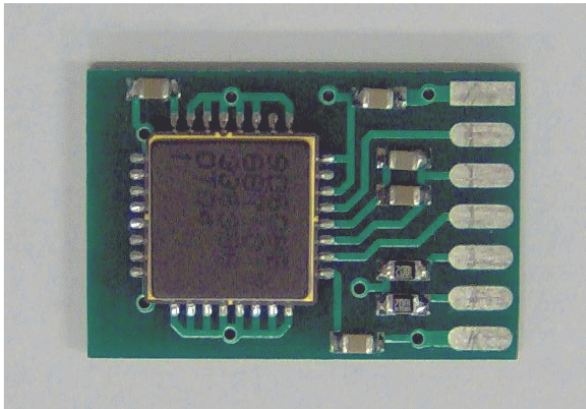

Figure 1. Top view of EVB90609 board.

EVB90609-x2 PCB is a small board, which uses the MLX90609 chip in a typical configuration. It can be directly connected to customer's system to ease the development process. The EVB90609-x2 boards provide the possibility to work both in analogue and in digital mode. Both modes are available on different connector pins of the board. Next to the MLX90609 chip the board includes several passive components which are recommended according to the typical schematic. The board communicates with outside world through edge-type 14 pin connector. Pin names, numbers and functions are explained in table 1.

## Detailed Description

### Variants

There are 3 variants of the EVB90609-x2 board, which differ only in MLX90609 chip type used (see Table 2).

Table 2. Board variants

Board	Order option "xx"	Chip type	Note
EVB90609	N2	MLX90609N2	75 deg/s full range
EVB90609	E2	MLX90609E2	150 deg/s full range
EVB90609	R2	MLX90609R2	300 deg/s full range

For more information about the MLX90609 chip and its operation, check the MLX90609 datasheets at [www.melexis.com](http://www.melexis.com).

### Pinout

Table 1. Pin out of the edge connector

Pin Number	Pin Name	Pin Function
1	VCC	Power pin +5V
2	VCC	Power pin +5V
3	VREF	Internal reference voltage
4	SCLK	Clock for SPI
5	OUTAR	Angular rate output voltage
6	-SS	Slave select for SPI (negative logic)
7	OUTTMP	Temperature output voltage
8	MISO	Master-input-slave-output signal for SPI
9	SLFT1	Self test selection pin 1
10	MOSI	Master-output-slave-input-signal for SPI
11	SLFT2	Self test selection pin 2
12	ERROR	Gyro internal error signalization
13	GND	Ground pin
14	GND	Ground pin

### Dimensions

A top view of EVB90609-x2 boards is represented in Figure 1. The dimensions of the boards are: 28 mm (length) x 18 mm (height) x 3.5 mm (thickness).

### Schematics

The electrical schematic of the EVB90609-x2 board is presented at Figure 2 as it is based on the typical schematic from MLX90609 datasheet.

The value of the capacitor C3 defines the output bandwidth of gyro. The -3dB bandwidth set by C3 is:

$$f_{OUT} = 0.16 / (R_{OUT} * C3), \text{ with } R_{OUT} = 200k\Omega \text{ (typ.)}$$

For instance, with C3=82nF the bandwidth is close to 10Hz.

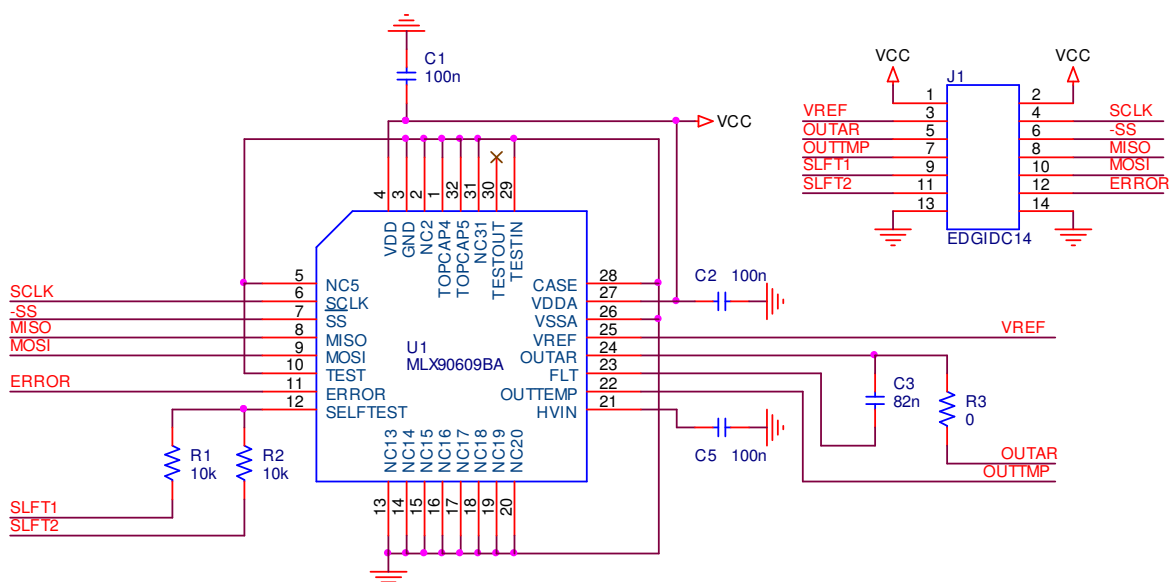

Figure 2. Electrical schematic of the MLX90609 boards

### Component placement and PCB Layout

Component placement at the board is presented at Figure 3.

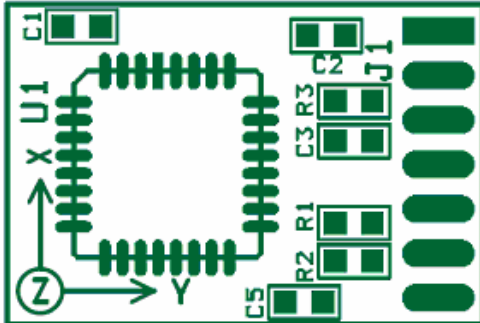

Figure 3. Component placement

The layouts of the top and bottom side of the board are presented at Figure 4.

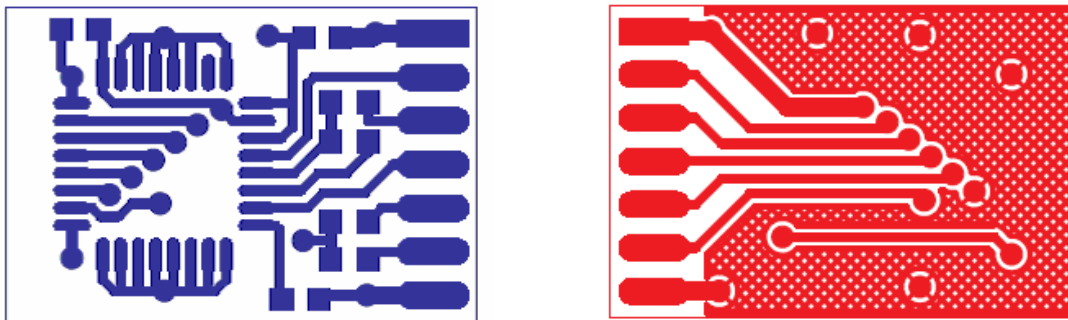

Figure 4. Board top (blue) and bottom (red) side layout.

### Revision history

Rev.001 from July 2007. Initial release.

Rev.002 from January 2008. Figure 2 Figure 3 and Figure 4 were adapted. Text at page 2 was corrected to reflect adapted board.

Rev.003 typos, naming conventions, order information

Rev.004 typo: R3->R2

Rev.005 typo: 50Hz -> close to 10Hz