

Table of contents

1	Introduction.....	2
2	Window lifter with anti-pinch and soft start/stop function.....	2
2.1	Introduction.....	2
2.2	Tips and hints.....	2
2.3	Schematic.....	3
3	Switch mode power supply for high power LEDs.....	4
3.1	Introduction.....	4
3.2	Tips and hints.....	4
3.3	Schematic.....	5
4	Flap control using MLX90316 for angle measurement.....	6
4.1	Introduction.....	6
4.2	Tips and hints.....	6
4.3	Schematic.....	7
5	Using MLX81100 in 24V applications.....	8
5.1	Introduction.....	8
5.2	Tips and hints.....	8
5.3	Schematic.....	9
6	Using PMOS in the high side.....	10
6.1	Introduction.....	10
6.2	Tips and hints.....	10
6.3	Schematic.....	11
7	Full Bridge Brushless DC Motor Driver with Hall Commutation.....	12
7.1	Introduction.....	12
7.2	Tips and hints.....	12
7.3	Schematic.....	13
8	Disclaimer.....	15

1 Introduction

This document is intended to give different example schematics and applications the MLX81100 could be used for.

All following schematics are sample schematics, which need to be adjusted depending on the target application and special requirements.

2 Window lifter with anti-pinch and soft start/stop function

2.1 Introduction

This example is intended to control a window lifter using relays. The main features are the possibility to implement:

- An anti-pinch functionality
- A soft start/stop functionality.

2.2 Tips and hints

1. The anti-pinch function could be realised using shunt current measurement.
2. The soft start/stop function could be realised by applying PWM to the N-FET in the low side.
3. The movement supervising (speed, position, direction) as well as an anti-pinch function could be realised using hall sensors.
4. The MLX81100 has high voltage inputs for reading in switches.
5. The Hall signals could be connected to Timer-capture inputs using general purpose IOs.

2.3 Schematic

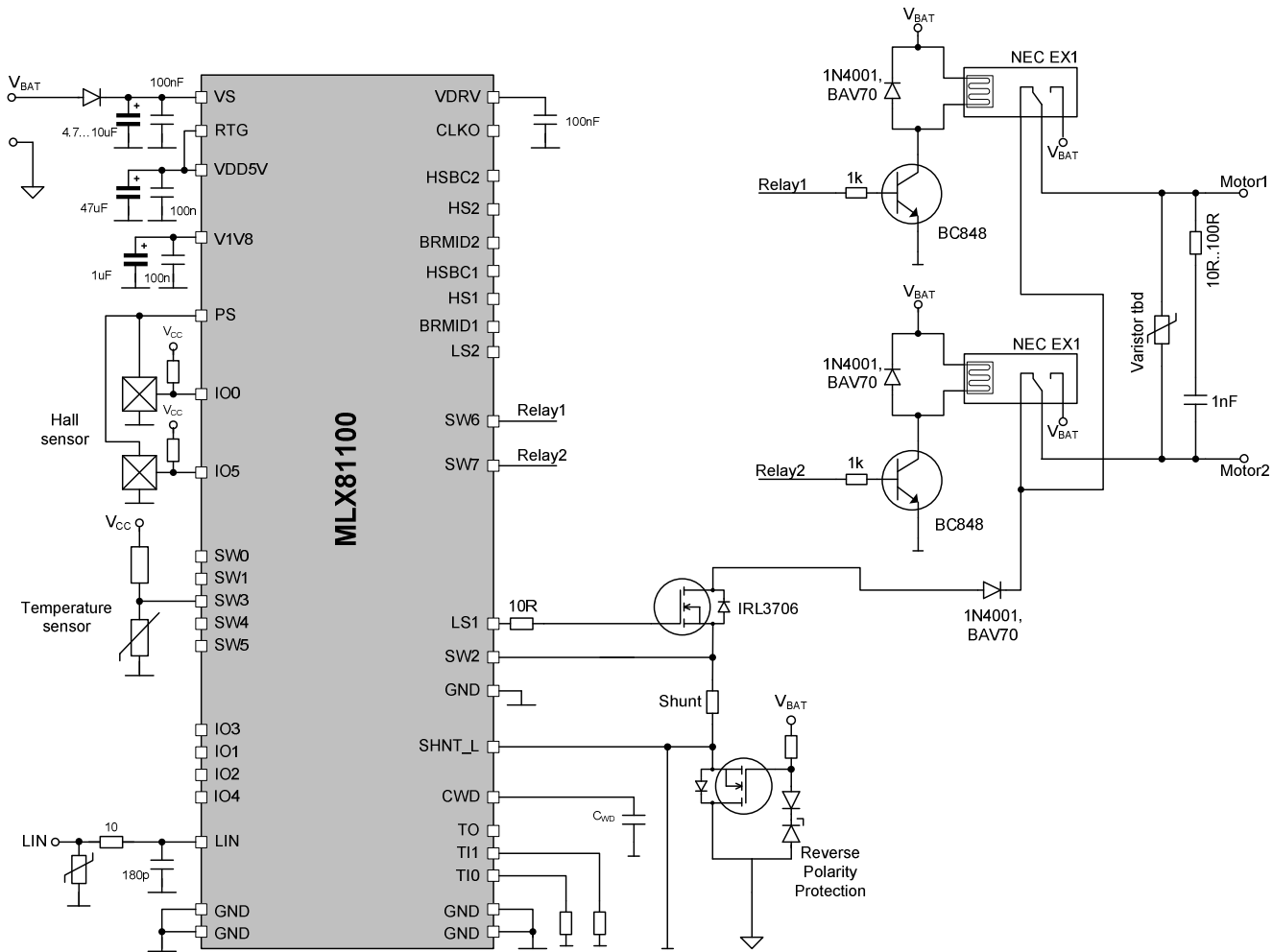

3 Switch mode power supply for high power LEDs

3.1 Introduction

This example is intended to show the usage of MLX81100 in a switch mode power supply to drive high power LEDs. The main features are:

- A PWM randomization in software
- A PWM frequency up to 75 kHz
- Efficiency
- The temperature supervision
- The secondary side current control via shunt measurement
- The tracking of the LED forward voltage to detect shorted LEDs
- The output power will be independent from Vbat and the temperature.

3.2 Tips and hints

1. The MLX81100 can apply the same PWM signal to more than one FET driver pin, this feature is needed to make the transformer work with the full H-bridge.
2. The PWM randomization can be done by software.
3. The PWM modules can be programmed to a max output frequency of 100 kHz.

3.3 Schematic

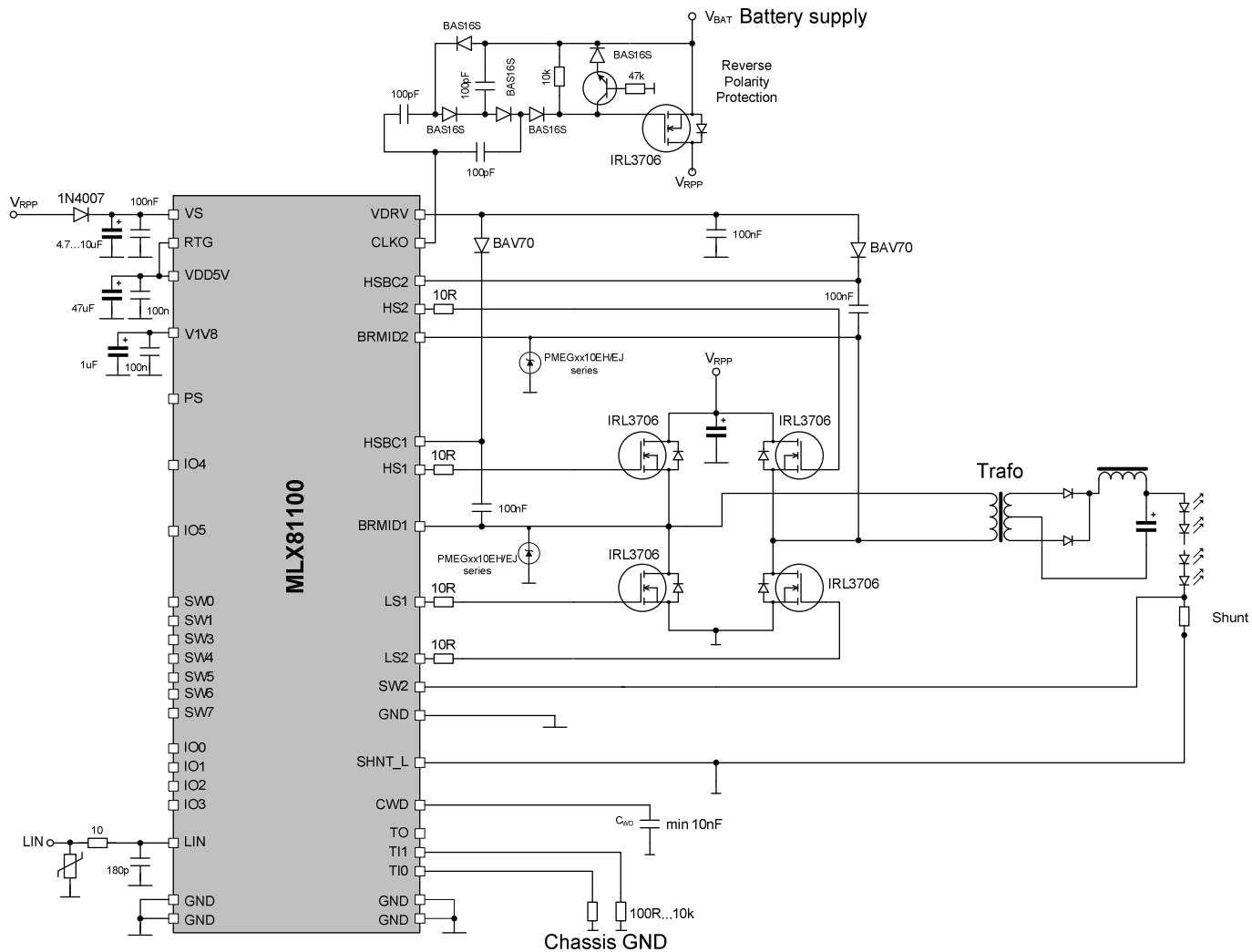

4 Flap control using MLX90316 for angle measurement

4.1 Introduction

This example is intended to show the usage of MLX81100 and MLX90316 in a flap control application. The main features are:

- The maximum Operating temperature for both ICs is up to 150 °C.
- A PWM control of the flap
- The shunt measurement is possible
- The MLX90316 allows up to 360 degrees angle measurement
- MLX90316 features different communication interfaces like Analog (Ratiometric), PWM, Serial Protocol
- Non-contacting rotary position sensor.

4.2 Tips and hints

1. The high side FETs can be driven up to true 100% PWM.
2. The PWM frequency is selectable from 100 Hz up to 100 kHz.

4.3 Schematic

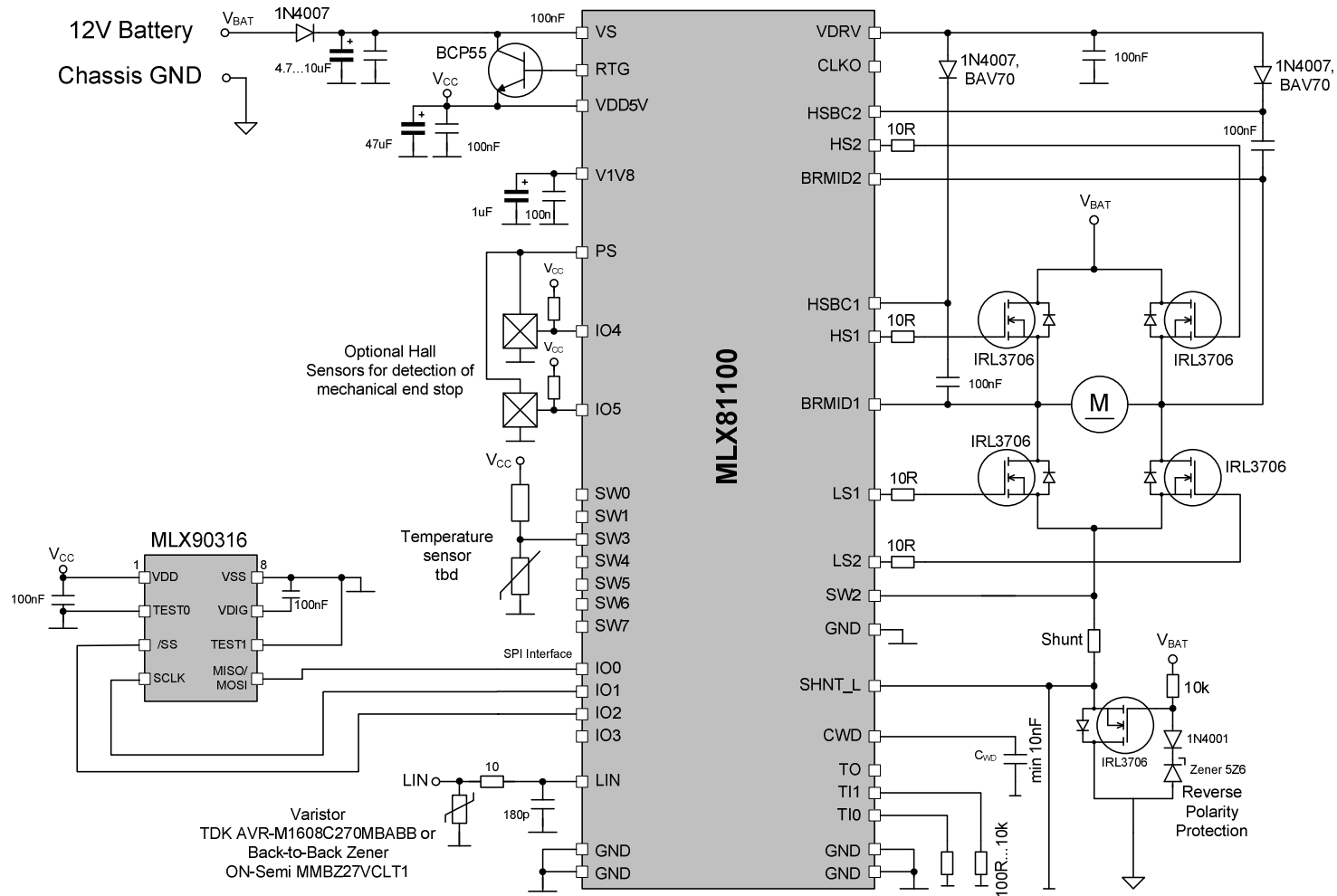

5 Using MLX81100 in 24V applications

5.1 Introduction

Considering some restrictions as well as the additionally needed ICs and components it's possible to use the MLX81100 to drive a DC-motor connected to a 24V supply. For proper operation two separate power supplies are needed, one for 12V and one for 24V. The MLX81100 can not be connected to the 24V supply continuously over life time.

5.2 Tips and hints

1. The possibility of driving 100% in the high side might be limited by the additionally used high side driver IC.
2. There are two separate power supplies needed for proper operation.
3. Observing the 24V supply could be done via ADC and external voltage divider.

5.3 Schematic

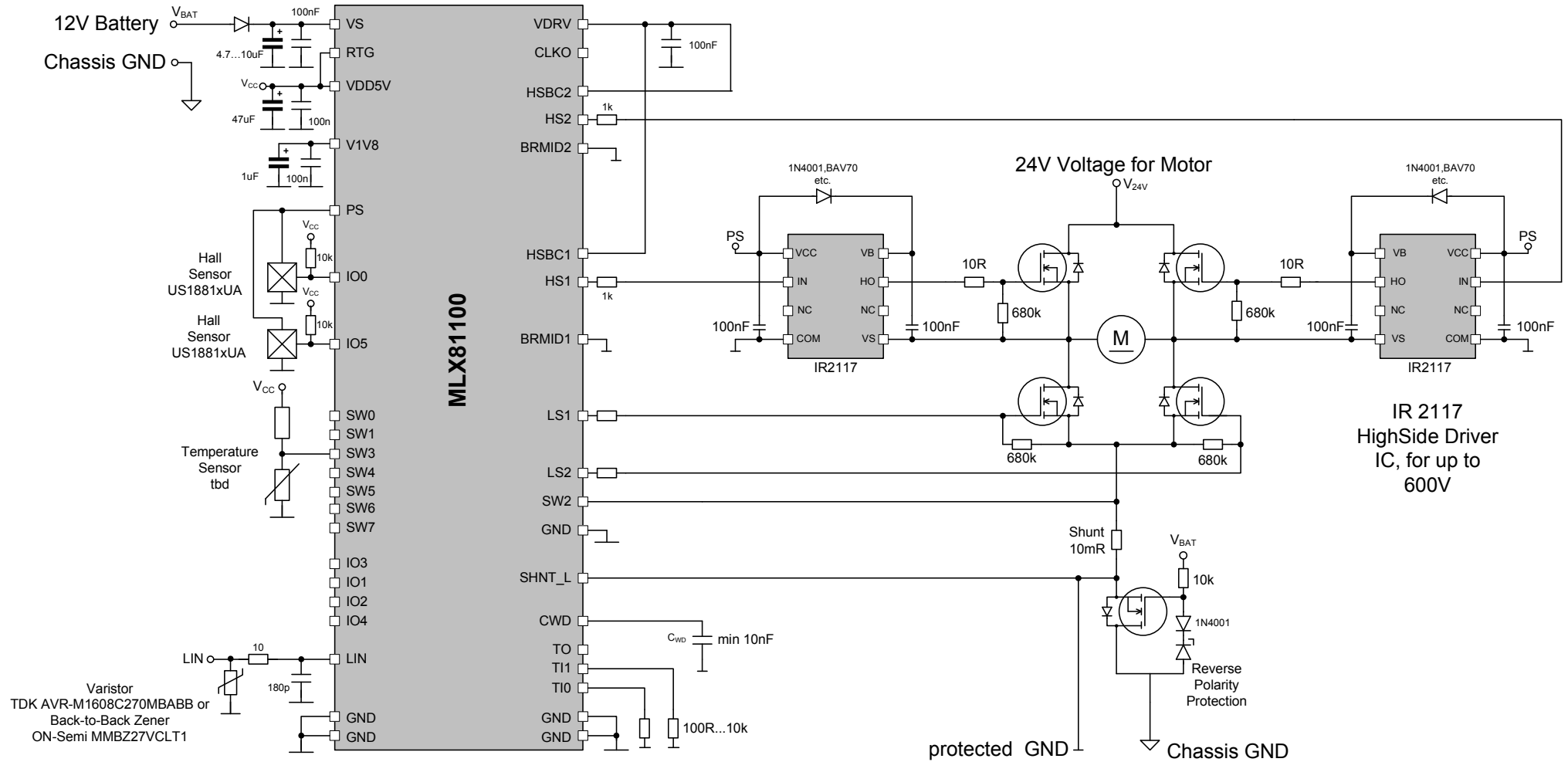

6 Using PMOS in the high side

6.1 Introduction

Considering some restrictions as well as the additionally needed components it's possible to use PMOS FETs in the high side of the h-bridge connected to MLX81100.

6.2 Tips and hints

1. The driving of PWM, even in the high-side, is possible. This feature is important regarding the thermal power dissipation of the high-side PMOS acting as a free wheel diode when PWM is applied to the low-side FET.
2. The IC bridge driver pins are decoupled from voltage transients like load dump.
3. This schematic features passive devices that will put the h-bridge in a defined secure state during sleep mode and in case the CPU is not working anymore.

6.3 Schematic

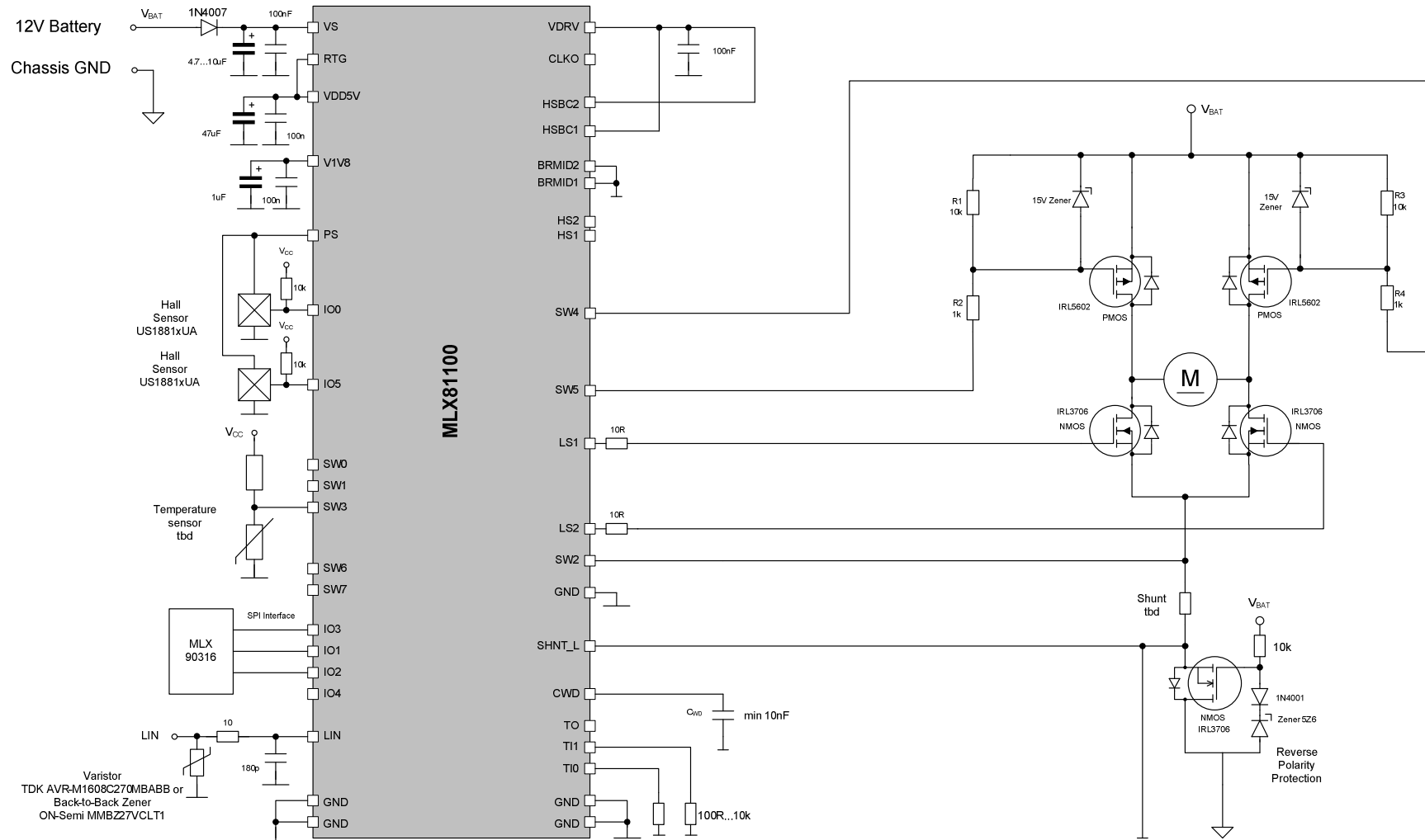

7 Full Bridge Brushless DC Motor Driver with Hall Commutation

7.1 Introduction

Connecting a full bridge to the MLX81100 it is possible to drive a simple bipolar BLDC motor. The commutation is done via a hall sensor.

7.2 Tips and hints

1. The MLX81100 can apply the same PWM signal to more than one FET driver pin, this feature is needed to make the transformer work with the full H-bridge.
2. The PWM modules can be programmed to a max output frequency of 100 kHz.
3. A PWM randomization can be done by software, e.g. for EMI or switching noise requirements.
4. The MLX81100 could help adding value to your application:
 - bidirectional communication interface, e.g. LIN
 - failure diagnosis features
 - temperature sensing
 - speed sensing
 - motor current sensing

7.3 Schematic

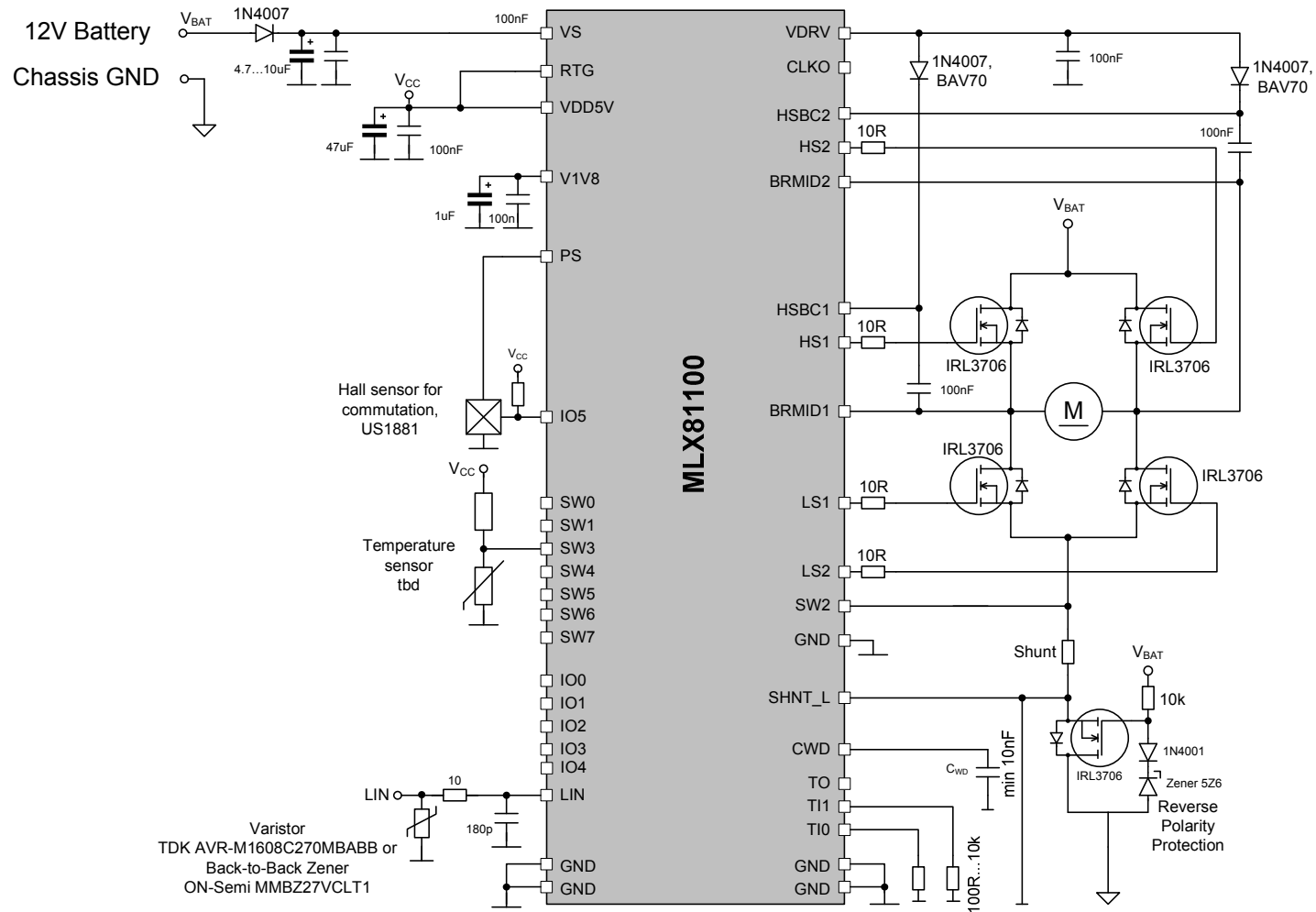

History record

Rev.	No.	Change	Date
1.0	1	Creation	04/09/08

8 Disclaimer

Devices sold by Melexis are covered by the warranty and patent indemnification provisions appearing in its Term of Sale. Melexis makes no warranty, express, statutory, implied, or by description regarding the information set forth herein or regarding the freedom of the described devices from patent infringement. Melexis reserves the right to change specifications and prices at any time and without notice. Therefore, prior to designing this product into a system, it is necessary to check with Melexis for current information. This product is intended for use in normal commercial applications. Applications requiring extended temperature range, unusual environmental requirements, or high reliability applications, such as military, medical life-support or life-sustaining equipment are specifically not recommended without additional processing by Melexis for each application.

The information furnished by Melexis is believed to be correct and accurate. However, Melexis shall not be liable to recipient or any third party for any damages, including but not limited to personal injury, property damage, loss of profits, loss of use, interrupt of business or indirect, special incidental or consequential damages, of any kind, in connection with or arising out of the furnishing, performance or use of the technical data herein. No obligation or liability to recipient or any third party shall arise or flow out of Melexis' rendering of technical or other services.

© 2007 Melexis NV. All rights reserved.

For the latest version of this document, go to our website at:

www.melexis.com

Or for additional information contact Melexis Direct:

Europe and Japan:
Phone: +32 1367 0495
E-mail: sales_europe@melexis.com

All other locations:
Phone: +1 603 223 2362
E-mail: sales_usa@melexis.com

ISO/TS 16949 and ISO14001 Certified