

Features and Benefits

PTC04 interface board for testing devices
 90215
 90224
 90244
 90251
 90277

Applications

Experimental tool for Lab and Prototyping
 Production Equipment for Serial Programming

Ordering Information

Part No.	Description
PTC04-DBHall	Default Daughter Board (Board + rear panel PTC04)

Accessoires

Part No.	Description
	DLL's for all supported products
	User Inter Faces for supported products

1. Functional Diagram

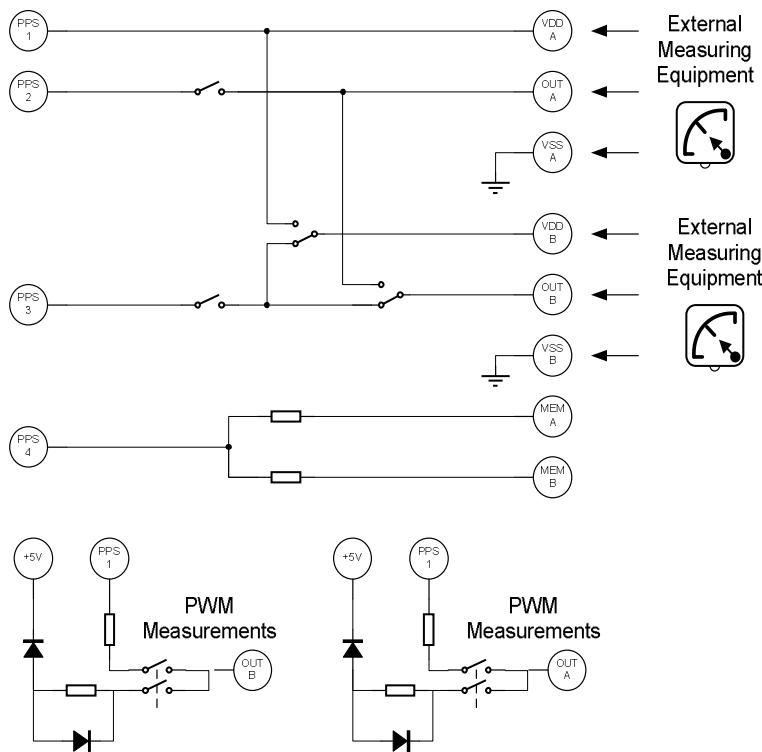

TABLE OF CONTENTS

FEATURES AND BENEFITS	1
APPLICATIONS	1
ORDERING INFORMATION	1
ACCESOIRES	1
1. FUNCTIONAL DIAGRAM	1
2. BOARD DESCRIPTION	3
2.1. BOARD LAYOUT	3
2.2. DESCRIPTION	4
2.3. DAUGHTER BOARD CONNECTORS	5
2.3.1. <i>Digital DB Connector (40 Pins)</i>	5
2.3.2. <i>Analog DB Connector (48 Pins)</i>	6
2.4. APPLICATION CONNECTOR	7
3. DISCLAIMER	8

2. Board description

2.1. Board Layout

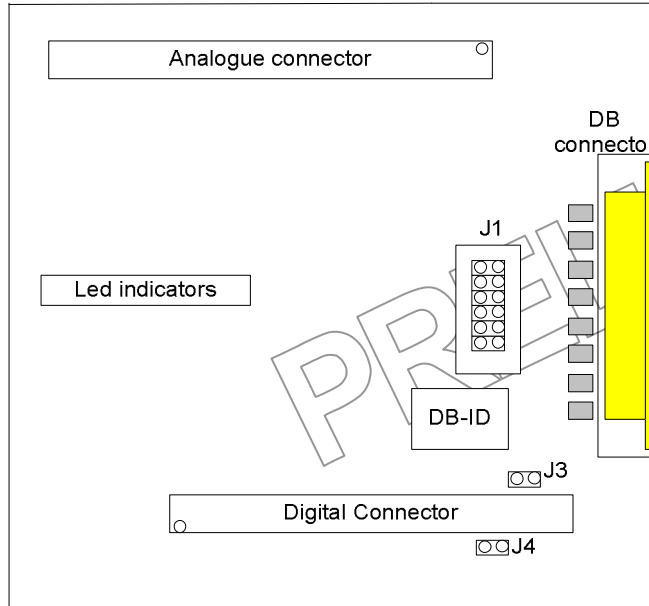
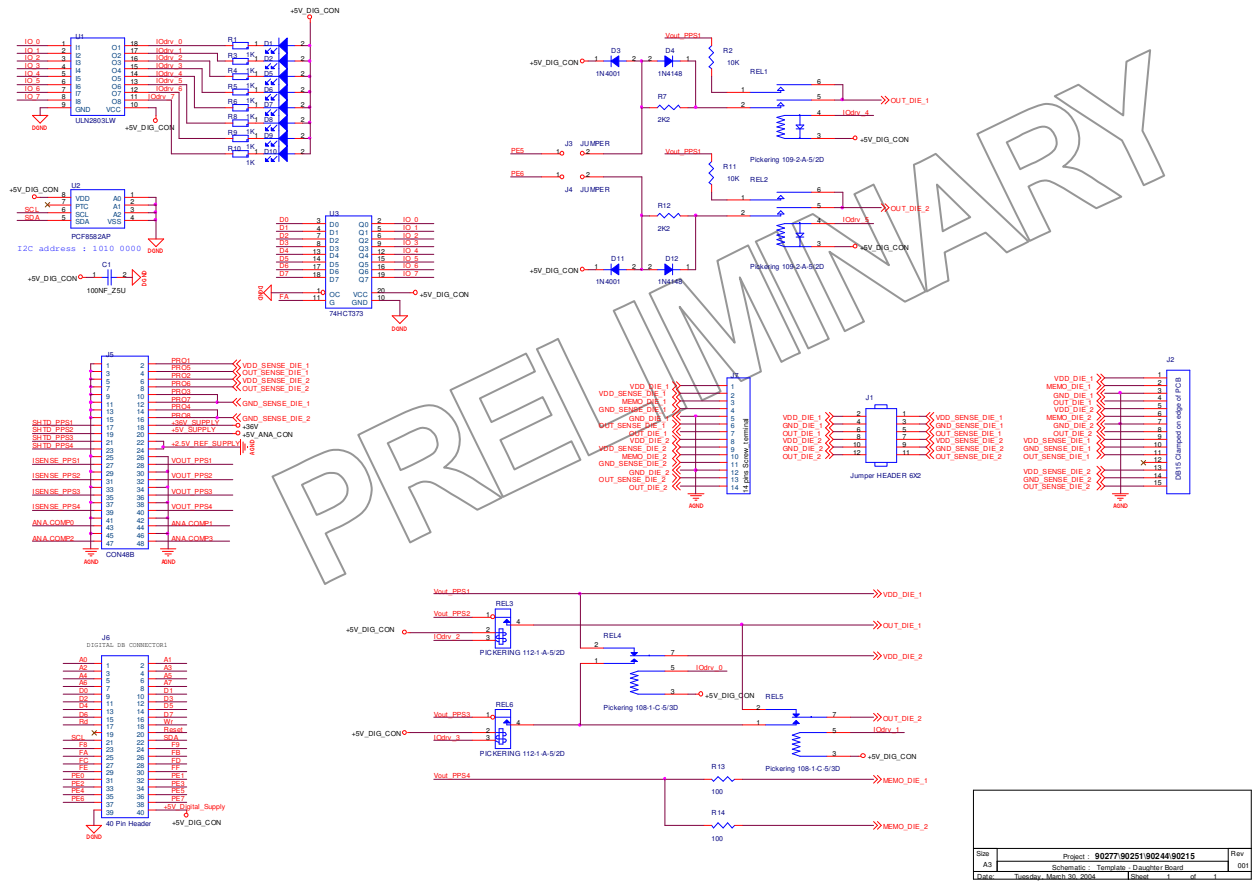

Figure 2-1

- **J1** : Jumpers to connect the measurement sense lines immediately to the force lines. These jumpers are needed when no force and sense is used.
- **J3,J4** : These jumpers are future expansions in order to support PWM output measurements and are not needed for testing the 90251 or the 90277.
- **DB-ID** : This ID keeps a few initial variables in mind. It allows for example to detect what DB is connected to the programmer and if the DB is not expired.
- **Analog and Digital connector** : See below for a detailed description
- **DB Connector** : Connector to the application. See below for details

2.2. Description



Size	Project	90277/90251-90244/90215	Rev
A3	Schematic	Template - Daughter Board	001
Date:	Tuesday, March 30, 2004	Sheet	1 of 1

2.3. Daughter board Connectors

The main board has two connectors to the interface with the application.

The PTC allows to add a full PCB in between. This daughter board can be mounted on the two connectors.

In some exceptional cases, a daughter board contains only a few wires from the Analog connector to the application connector

The connection on the connectors are described below

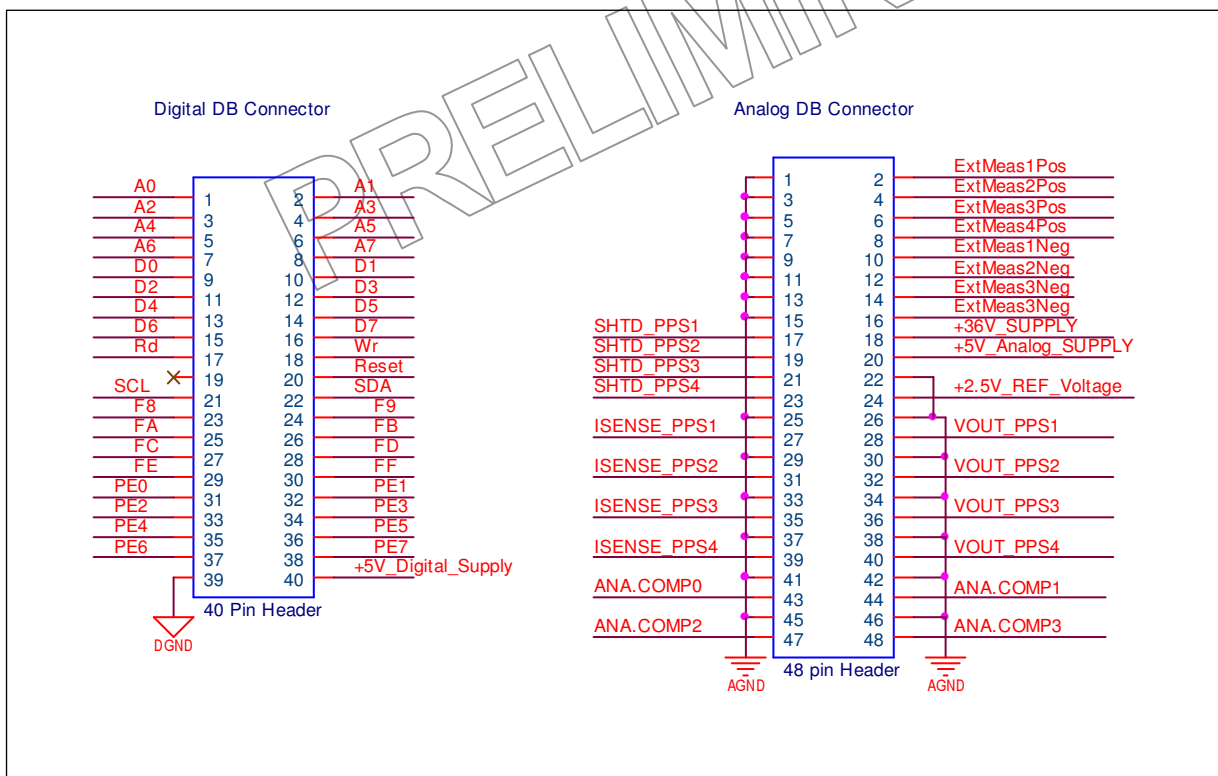

2.3.1. Digital DB Connector (40 Pins)

Mainly, the digital connector is meant to expand the programmer to extra needs.

Address lines A0-A7 together with the Map Select Lines F8-FF allows to direct access an area of 2 K

Examples would be adding a simple addressed I/O register by using the selection lines.

If more complexity is needed, a full FPGA can be mounted on the DB board

Pins	Names	Description
1 – 8	A0 – A7	Address lines
9 – 16	D0 – D7	Data Lines active during Rd or Wr signals
17	Rd	Read : A negative pulse will indicate a sampling of the data on the Data Bus
18	Wr	Write : A Negative pulse will indicate when data is available on the Data Bus
20	Reset	This signal goes low by powering the PTC or by pressing the reset button. This line can be pulled low by application. Check firmware documentation for resetting by software.
21-22	SCL / SDA	I2c Bus
23-30	F8,F9,...,FF	CS lines when the address areas are accessed
31-38	Port E	Note: These pins are limited to 5 Volt input/output!!!!

		The full Port E of the Atmega core is mounted to these pins. This allows us to use advanced features like PWM, UARTS, Time Measurements, etc.... By using firmware that supports these, functions, really nice application specific requirements can be fulfilled.
39	Dgnd	Digital Ground
40	+5V Digital	5 Volt Digital Supply. Maximum current to get out of this supply:mA

Note: All the pins are limited to 5 Volt input/output!!!! However, there are Protections, please take precautions in order to avoid damage of the main board.

2.3.2. Analog DB Connector (48 Pins)

Mainly, the analog connector provides all the analog signals and measure possibilities.

Pins	Names	Description
28,32,36	PPS 1-3	Output of the Programmable Supplies
40	PPS 4	Output of the Fast DAC Programmable Power Supply
27,31,35,39	Isense_PP1-4	Outputs (Driver outputs before Rsens) for current evaluations. These outputs could be used to connect to the analog comparators in order to create fast digital signals based on current.
2,4,6,8	ExtMeas1-4Pos	There are 4 differential inputs for making measurements
10,12,14,16	ExtMeas1_4Neg	The negative inputs of ExtMeas1-4Pos
17,19,21,23	Shtd_PPS1-4	Outputs that shows the status of the Drivers. Signals are meant to connect LED's to put the front panel
43,44,47,48	AnaComp0-3	See *Note. Input (limited to 5V) Fast Level comparators in order to remove time consuming measurement
18	+35V_Supply	Supply to extend the daughter board with some extra drivers
20	+5V_Analog	Supply to extend the daughter board with some extra hardware
24	+2.5V Ref	Output of internal reference
All other	AGND	Analog Ground

Note: All the pins are limited to 35 Volt input/output!!!! However, there are Protections, please take precautions in order to avoid damage of the main board.

* Note: Some pins are protected and limited to 5 Volt!!!! However, there are Protections, please take precautions in order to avoid damage of the main board.

2.4. Application Connector

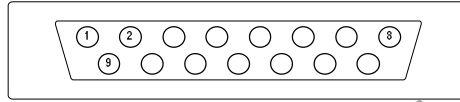

Pins	Names	Description
1	VDD A	Supply Device A
2	MEMO A	
3	VSS A	Analog Ground Device A
4	OUT A	Output Device A
5	VDD B	Supply Device B
6	MEMO B	
7	VSS B	Analog Ground Device B
8	OUT B	Output Device B
9	SENSING VDD A	Sensing Supply Device A
10	SENSING VSS A	Sensing Analog Ground A
11	SENSING OUT A	Sensing Output
12	NC	Not Connected
13	SENSING VDD B	Sensing Supply Device B
14	SENSING VSS B	Sensing Analog Ground B
15	SENSING OUT B	Sensing Output Device B

3. Disclaimer

Devices sold by Melexis are covered by the warranty and patent indemnification provisions appearing in its Term of Sale. Melexis makes no warranty, express, statutory, implied, or by description regarding the information set forth herein or regarding the freedom of the described devices from patent infringement. Melexis reserves the right to change specifications and prices at any time and without notice. Therefore, prior to designing this product into a system, it is necessary to check with Melexis for current information. This product is intended for use in normal commercial applications. Applications requiring extended temperature range, unusual environmental requirements, or high reliability applications, such as military, medical life-support or life-sustaining equipment are specifically not recommended without additional processing by Melexis for each application.

The information furnished by Melexis is believed to be correct and accurate. However, Melexis shall not be liable to recipient or any third party for any damages, including but not limited to personal injury, property damage, loss of profits, loss of use, interrupt of business or indirect, special incidental or consequential damages, of any kind, in connection with or arising out of the furnishing, performance or use of the technical data herein. No obligation or liability to recipient or any third party shall arise or flow out of Melexis' rendering of technical or other services.

© 2002 Melexis NV. All rights reserved.

For the latest version of this document, go to our website at:

www.melexis.com

Or for additional information contact Melexis Direct:

Europe and Japan:	All other locations:
Phone: +32 13 67 04 95	Phone: +1 603 223 2362
E-mail: sales_europe@melexis.com	E-mail: sales_usa@melexis.com