

## Features

- Double-conversion superhet architecture for high degree of image rejection
- FSK demodulation with phase-coincidence demodulator
- Low current consumption in active mode and very low standby current
- Switchable LNA gain for improved dynamic range
- RSSI allows signal strength indication and ASK detection
- 32-pin Low profile Quad Flat Package (LQFP)

## Ordering Information

Part No.	Temperature Code	Package Code	
Part Number	Temperature Code	Package Code	Delivery Form
TH71112	E (-40 °C to 85 °C) C (-10 °C to 70 °C)	NE (LQFP32)	250 pc/tray 2000 pc/T&R

## Application Examples

- General digital data transmission
- Tire Pressure Monitoring Systems (TPMS)
- Remote Keyless Entry (RKE)
- Wireless access control
- Alarm and security systems
- Garage door openers
- Remote Controls
- Home and building automation
- Low-power telemetry systems

## Pin Description

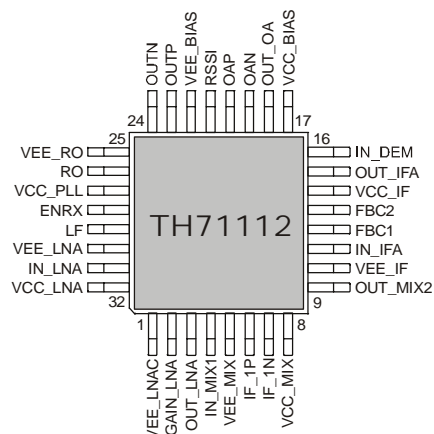

## General Description

The TH71112 FSK/ASK double-conversion superheterodyne receiver IC is designed for applications in the European 868 MHz industrial-scientific-medical (ISM) band, according to the EN 300 220 telecommunications standard. It can also be used for any other system with carrier frequencies ranging from 750 MHz to 990 MHz (e.g. for applications according to FCC part 15).

## Document Content

<b>1</b>	<b>Theory of Operation</b> .....	<b>3</b>
1.1	General.....	3
1.2	Technical Data Overview.....	3
1.3	Block Diagram .....	4
1.4	Mode Configurations .....	4
1.5	LNA GAIN Control .....	4
1.6	Frequency Planning.....	4
1.6.1	Selected Frequency Plans.....	5
1.6.2	Maximum Frequency Coverage.....	5
<b>2</b>	<b>Pin Definitions and Descriptions</b> .....	<b>6</b>
<b>3</b>	<b>Technical Data</b> .....	<b>9</b>
3.1	Absolute Maximum Ratings.....	9
3.2	Normal Operating Conditions .....	9
3.3	Crystal Parameters.....	9
3.4	DC Characteristics.....	10
3.5	AC System Characteristics.....	11
<b>4</b>	<b>Test Circuits</b> .....	<b>12</b>
4.1	Standard FSK Reception.....	12
4.1.1	Standard FSK Application Circuit .....	12
4.1.2	Standard FSK Component List.....	13
4.2	Narrow Band FSK Reception.....	14
4.2.1	Narrow Band FSK Application Circuit.....	14
4.2.2	Narrow Band FSK Component List.....	15
4.3	ASK Reception .....	16
4.3.1	ASK Application Circuit.....	16
4.3.2	ASK Component List.....	17
<b>5</b>	<b>Package Description</b> .....	<b>18</b>
5.1	Soldering Information .....	18
<b>6</b>	<b>Reliability Information</b> .....	<b>19</b>
<b>7</b>	<b>ESD Precautions</b> .....	<b>19</b>
<b>8</b>	<b>Disclaimer</b> .....	<b>20</b>

## 1 Theory of Operation

### 1.1 General

With the TH71112 receiver chip, various circuit configurations can be arranged in order to meet a number of different customer requirements. For FSK reception the IF tank used in the phase coincidence demodulator can be constituted by an external ceramic discriminator. In ASK configuration, the RSSI signal is fed to an ASK detector, which is constituted by the operational amplifier.

The superheterodyne configuration is double conversion where MIX1 and MIX2 are driven by the internal local oscillator signals LO1 and LO2, respectively. This allows a high degree of image rejection, achieved in conjunction with an RF front-end filter. Efficient RF front-end filtering is realized by using a SAW, ceramic or helix filter in front of the LNA and by adding an LC filter at the LNA output.

A single-conversion variant, called TH71111, is also available. Both Receiver ICs have the same die. At the TH71111 the second mixer MIX2 operates as an amplifier.

The TH71112 receiver IC consists of the following building blocks:

- PLL synthesizer (PLL SYNTH) for generation of the first and second local oscillator signals LO1 and LO2, parts of the PLL SYNTH are: the high-frequency VCO1, the feedback dividers DIV\_16 and DIV\_2, a phase-frequency detector (PFD) with charge pump (CP) and a crystal-based reference oscillator (RO)
- Low-noise amplifier (LNA) for high-sensitivity RF signal reception
- First mixer (MIX1) for down-conversion of the RF signal to the first IF (IF1)
- Second mixer (MIX2) for down-conversion of the IF1 to the second IF (IF2)
- IF amplifier (IFA) to amplify and limit the IF2 signal and for RSSI generation
- Phase coincidence demodulator (DEMOD) with third mixer (MIX3) to demodulate the IF signal
- Operational amplifier (OA) for data slicing, filtering and ASK detection
- Bias circuitry for bandgap biasing and circuit shutdown

### 1.2 Technical Data Overview

- ❑ Input frequency range: 750 MHz to 990 MHz
- ❑ Power supply range: 2.3 V to 5.5 V @ ASK
- ❑ Temperature range: -40 °C to +85 °C
- ❑ Standby current: 50 nA
- ❑ Operating current: 7.5 mA @ low gain mode  
9.2 mA @ high gain mode
- ❑ Sensitivity: -112 dBm @ ASK 1)  
-106 dBm @ FSK 2)
- ❑ Maximum data rate: 260 kbps NRZ @ ASK  
180 kbps NRZ @ FSK
- ❑ Range of IF1: 10 MHz to 80 MHz
- ❑ Range of IF2: 400 kHz to 22 MHz
- ❑ Maximum input level: -10 dBm @ ASK  
0 dBm @ FSK
- ❑ Image rejection: > 60 dB (e.g. with 868.3 MHz SAW front-end filter and at 10.7 MHz IF2)
- ❑ Spurious emission: < -70 dBm
- ❑ Input frequency acceptance range: up to  $\pm 100$  kHz
- ❑ RSSI range: 70 dB
- ❑ FSK deviation range:  $\pm 2.5$  kHz to  $\pm 80$  kHz

- 1) at 4 kbps NRZ, BER =  $3 \cdot 10^{-3}$ , 180 kHz IF filter BW, without SAW front-end-filter loss
- 2) at 4 kbps NRZ, BER =  $3 \cdot 10^{-3}$ ,  $\pm 20$  kHz FSK deviation, 180 kHz IF filter BW, without SAW front-end-filter loss



By configuring the TH71112 for double conversion and using its internal PLL synthesizer with fixed feedback divider ratios of N1 = 16 (DIV\_16) and N2 = 2 (DIV\_2), four types of down-conversion are possible: low-side injection of LO1 and LO2 (**low-low**), LO1 low-side and LO2 high-side (**low-high**), LO1 high-side and LO2 low-side (**high-low**) or LO1 and LO2 high-side (**high-high**). The following table summarizes some equations that are useful to calculate the crystal reference frequency (REF), the first IF (IF1) and the VCO1 or first LO frequency (LO1), respectively, for a given RF and second IF (IF2).

Injection type	high-high	low-low	high-low	low-high
REF	$(RF - IF2)/30$	$(RF - IF2)/34$	$(RF + IF2)/30$	$(RF + IF2)/34$
LO1	$32 \bullet REF$	$32 \bullet REF$	$32 \bullet REF$	$32 \bullet REF$
IF1	$LO1 - RF$	$RF - LO1$	$LO1 - RF$	$RF - LO1$
LO2	$2 \bullet REF$	$2 \bullet REF$	$2 \bullet REF$	$2 \bullet REF$
IF2	$LO2 - IF1$	$IF1 - LO2$	$IF1 - LO2$	$LO2 - IF1$

### 1.6.1 Selected Frequency Plans

The following table depicts crystal, LO and image signals considering the examples of 868.3 MHz and 915 MHz RF reception at IF2 = 10.7 MHz. The columns in bold depict the selected frequency plans to receive at 868.3 MHz and 915 MHz, respectively.

Signal type	RF = 868.3 MHz	RF = 868.3 MHz	RF = 868.3 MHz	RF = 868.3 MHz	RF = 915 MHz	RF = 915 MHz	RF = 915 MHz	RF = 915 MHz
Injection type	high-high	<b>low-low</b>	high-low	low-high	high-high	<b>low-low</b>	high-low	low-high
REF / MHz	28.58667	<b>25.22353</b>	29.3	25.85294	30.14333	<b>26.59706</b>	30.85667	27.22647
LO1 / MHz	914.77333	<b>807.15294</b>	937.6	827.29412	964.58667	<b>851.10588</b>	987.41333	871.24706
IF1 / MHz	46.47333	<b>61.14706</b>	69.3	41.00588	49.58667	<b>63.89412</b>	72.41333	43.75294
LO2 / MHz	57.17333	<b>50.44706</b>	58.6	51.70588	60.28667	<b>53.19412</b>	61.71333	54.45294
RF image/MHz	961.24667	<b>746.00588</b>	1006.9	786.28824	1014.17	<b>787.21176</b>	1059.83	827.49412
IF1 image/MHz	67.87333	<b>39.74706</b>	47.9	62.40588	70.98667	<b>42.49412</b>	51.01333	65.15294

### 1.6.2 Maximum Frequency Coverage

Parameter	f <sub>min</sub>	f <sub>max</sub>
Injection type	high-low	low-low
RF / MHz	739.3	998.825
REF / MHz	25.0	29.0625
LO1 / MHz	800	930
IF1 / MHz	60.7	68.825
LO2 / MHz	50.0	58.125
IF2 / MHz	10.7	10.7

The selection of the reference crystal frequency is based on some assumptions. As for example: the first IF and the image frequencies should not be in a radio band where strong interfering signals might occur (because they could represent parasitic receiving signals), the LO1 signal should be in the range of 800 MHz to 930 MHz (because this is the optimum frequency range of the VCO1). Furthermore the first IF should be as high as possible to achieve highest RF image rejection.

## 2 Pin Definitions and Descriptions

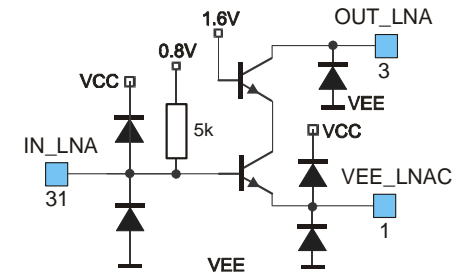
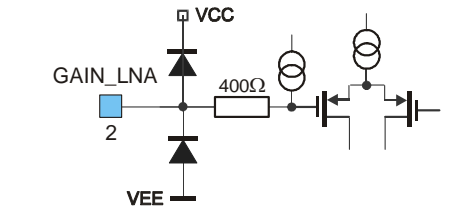
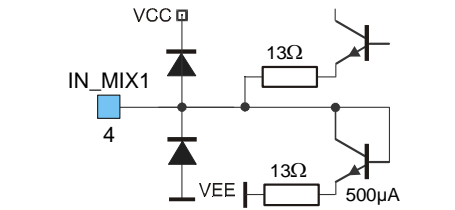
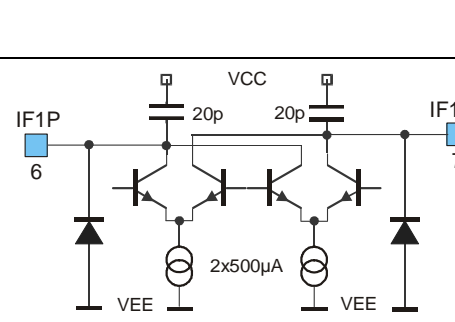
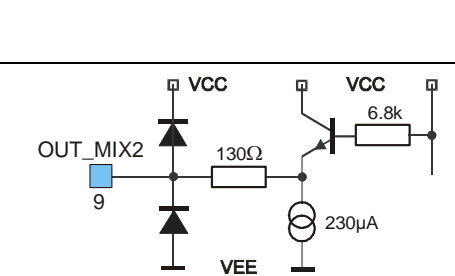
Pin No.	Name	I/O Type	Functional Schematic	Description
3	OUT_LNA	analog output		LNA open-collector output, to be connected to external LC tank that resonates at RF
31	IN_LNA	analog input		LNA input, approx. 26Ω single-ended
1	VEE_LNAC	ground		ground of LNA core (cas-code)
2	GAIN_LNA	analog input		LNA gain control (input with hysteresis)  RX standby: no pull-up RX active: pull-up
4	IN_MIX1	analog input		MIX1 input, approx. 33Ω single-ended
5	VEE_MIX	ground		ground of MIX1 and MIX2
6	IF1P	analog I/O		open-collector output, to be connected to external LC tank that resonates at first IF
7	IF1N	analog I/O		open-collector output, to be connected to external LC tank that resonates at first IF
8	VCC_MIX	supply		positive supply of MIX1 and MIX2
9	OUT_MIX2	analog output		MIX2 output, approx. 330Ω output impedance
10	VEE_IF	ground		ground of IFA and DEMOD

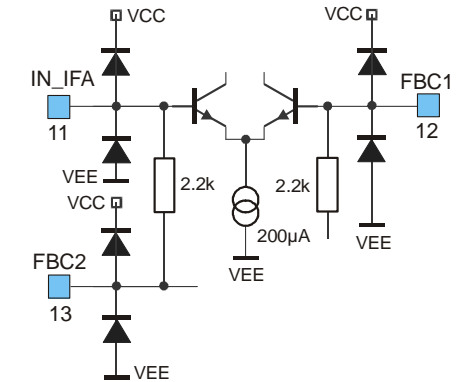
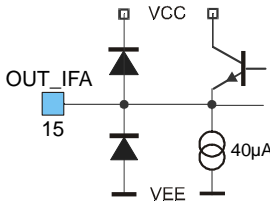
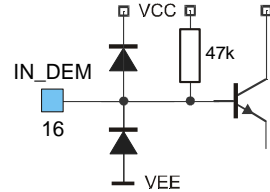
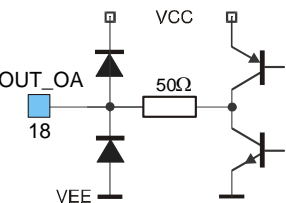
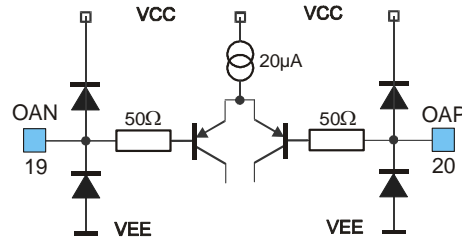
Pin No.	Name	I/O Type	Functional Schematic	Description
11	IN_IFA	analog input		IFA input, approx. 2.2k $\Omega$ input impedance
12	FBC1	analog I/O		to be connected to external IFA feedback capacitor
13	FBC2	analog I/O		to be connected to external IFA feedback capacitor
14	VCC_IF	supply		positive supply of IFA and DEMOD
15	OUT_IFA	analog I/O		IFA output and MIX3 input (of DEMOD)
16	IN_DEM	analog input		DEMOD input, to MIX3 core
17	VCC_BIAS	supply		positive supply of general bias system and OA
18	OUT_OA	analog output		OA output, 40uA current drive capability
19	OAN	analog input		negative OA input
20	OAP	analog input		positive OA input

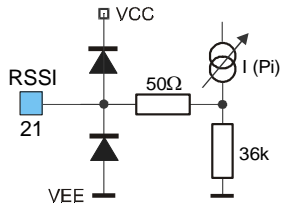
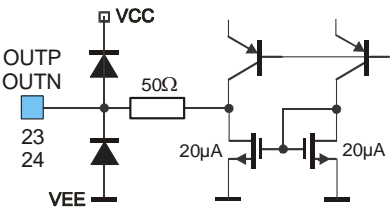
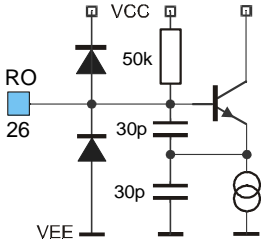
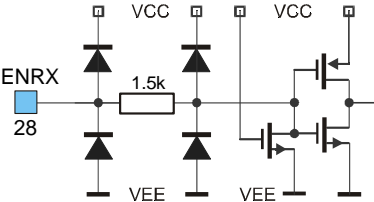
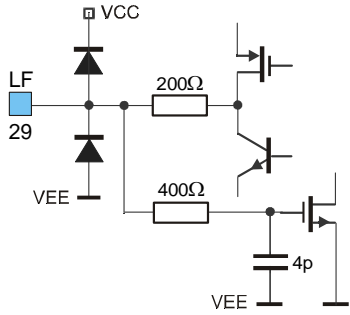
Pin No.	Name	I/O Type	Functional Schematic	Description
21	RSSI	analog output		RSSI output, for RSSI and ASK detection, approx. 36kΩ output impedance
22	VEE_BIAS	ground		ground of general bias system and OA
23	OUTP	analog output		FSK positive output, output impedance of 100kΩ to 300kΩ
24	OUTN	analog output		FSK negative output, output impedance of 100kΩ to 300kΩ
25	VEE_RO	ground		ground of DIV, PFD, RO and charge pump
26	RO	analog input		RO input, Colpitts type oscillator with internal feedback capacitors
27	VCC_PLL	supply		positive supply of DIV, PFD, RO and charge pump
28	ENRX	digital input		mode control input, CMOS-compatible with internal pull-down circuit
29	LF	analog I/O		charge pump output and VCO1 control input
30	VEE_LNA	ground		ground of LNA biasing
32	VCC_LNA	supply		positive supply of LNA biasing

### 3 Technical Data

#### 3.1 Absolute Maximum Ratings

Parameter	Symbol	Condition / Note	Min	Max	Unit
Supply voltage	$V_{CC}$		0	7.0	V
Input voltage	$V_{IN}$		- 0.3	$V_{CC}+0.3$	V
Input RF level	$P_{iRF}$	@ LNA input		10	dBm
Storage temperature	$T_{STG}$		-40	+125	°C
Junction temperature	$T_J$			+150	°C
Thermal Resistance	$R_{thJA}$			60	K/W
Power dissipation	$P_{diss}$			0.1	W
Electrostatic discharge	$V_{ESD1}$	human body model, 3)	-1.0	+1.0	kV
	$V_{ESD2}$	human body model, 4)	-0.75	+0.75	

3) all pins except OUT\_LNA, IF1P and IF1N

4) pin OUT\_LNA, IF1P and IF1N

#### 3.2 Normal Operating Conditions

Parameter	Symbol	Condition	Min	Max	Unit
Supply voltage	$V_{CC, FSK}$	0 °C to 85 °C	2.5	5.5	V
		-20 °C to 85 °C	2.6	5.5	
		-40 °C to 85 °C	2.7	5.5	
	$V_{CC, ASK}$	-40 °C to 85 °C	2.3	5.5	
Operating temperature	$T_A$	TH71112 E	-40	+85	°C
		TH71112 C	-10	+70	
Input low voltage (CMOS)	$V_{IL}$	ENRX pin		$0.3 \cdot V_{CC}$	V
Input high voltage (CMOS)	$V_{IH}$	ENRX pin	$0.7 \cdot V_{CC}$		V
Input frequency range	$f_i$		739.3	998.8	MHz
First IF range	$f_{IF1}$		10	80	MHz
Second IF range	$f_{IF2}$		0.4	22	MHz
XOSC frequency	$f_{ref}$	set by the crystal	25	29.063	MHz
VCO frequency	$f_{LO}$	$f_{LO} = 16 \cdot f_{ref}$	800	930	MHz
Frequency deviation	$\Delta f$		$\pm 2.5$	$\pm 80$	kHz
FSK data rate	$R_{FSK}$	NRZ, C15 = NIP, 5)		180	kbps
ASK data rate	$R_{ASK}$	NRZ, C16 = NIP, 5)		260	kbps

5)  $B_{IF} = 400$  kHz,  $P_{IN} = -90$  dBm

#### 3.3 Crystal Parameters

Parameter	Symbol	Condition	Min	Max	Unit
Crystal frequency	$f_0$	fundamental mode, AT	25	29.063	MHz
Load capacitance	$C_L$		10	15	pF
Static capacitance	$C_0$			7	pF
Series resistance	$R_1$			50	$\Omega$

### 3.4 DC Characteristics

all parameters under normal operating conditions, unless otherwise stated;  
typical values at  $T_A = 23\text{ }^\circ\text{C}$  and  $V_{CC} = 3\text{ V}$

Parameter	Symbol	Condition	Min	Typ	Max	Unit
<b>Operating Currents</b>						
Standby current	$I_{SBY}$	ENRX=0		50	100	nA
Supply current at low gain	$I_{CC, low}$	ENRX=1, GAIN_LNA=1, TH71112 E	4.5	7.5	12.0	mA
		ENRX=1, GAIN_LNA=1, TH71112 C			11.6	
Supply current at high gain	$I_{CC, high}$	ENRX=1, GAIN_LNA=0, TH71112 E	5.0	9.2	14.0	mA
		ENRX=1, GAIN_LNA=0, TH71112 C			13.5	
<b>Digital Pin Characteristics</b>						
Input low voltage CMOS	$V_{IL}$	ENRX pin	-0.3		$0.3 \cdot V_{CC}$	V
Input high voltage CMOS	$V_{IH}$	ENRX pin	$0.7 \cdot V_{CC}$		$V_{CC} + 0.3$	V
Pull down current ENRX pin	$I_{PDEN}$	ENRX=1	0.1	2	10	$\mu\text{A}$
Low level input current ENRX pin	$I_{INLEN}$	ENRX=0			0.05	$\mu\text{A}$
<b>Analog Pin Characteristics</b>						
High level input current GAIN_LNA pin	$I_{INHAIN}$	GAIN_LNA=1			0.05	$\mu\text{A}$
Pull up current GAIN_LNA pin active	$I_{PUGAINa}$	GAIN_LNA=0 ENRX=1	0.08	0.15	0.3	$\mu\text{A}$
Pull up current GAIN_LNA pin standby	$I_{PUGAINs}$	GAIN_LNA=0 ENRX=0			0.05	$\mu\text{A}$
High gain input voltage	$V_{IHGAIN}$	ENRX=1			0.7	V
Low gain input voltage	$V_{ILGAIN}$	ENRX=1	1.5			V
<b>Opamp Characteristics</b>						
Opamp input offset voltage	$V_{offs}$		-35		35	mV
Opamp input offset current	$I_{offs}$	$I_{OAP} - I_{OAN}$	-50		50	nA
Opamp input bias current	$I_{bias}$	$0.5 \cdot (I_{OAP} + I_{OAN})$	-150		150	nA
<b>RSSI Characteristics</b>						
RSSI voltage at low input level	$V_{RSSI, low}$	$P_i = -65\text{ dBm}$ , GAIN_LNA=1	0.5	1.0	1.5	V
RSSI voltage at high input level	$V_{RSSI, high}$	$P_i = -35\text{ dBm}$ , GAIN_LNA=1	1.2	1.9	2.5	V

### 3.5 AC System Characteristics

all parameters under normal operating conditions, unless otherwise stated;  
 typical values at  $T_A = 23\text{ }^\circ\text{C}$  and  $V_{CC} = 3\text{ V}$ ,  
 RF at 868.3 MHz; SAW frond-end filter loss and IF at 10.7 MHz;  
 all parameters based on test circuits as shown in Fig. 2, Fig.3 and Fig. 5

Parameter	Symbol	Condition	Min	Typ	Max	Unit
<b>Receive Characteristics</b>						
Input sensitivity – FSK (standard)	$P_{\min, ST}$	$B_{IF} = 180\text{kHz}$ , $\Delta f = \pm 20\text{kHz}$ , 4kbps NRZ, $BER \leq 3 \cdot 10^{-3}$ , 6)		-103		dBm
Input sensitivity – FSK (narrow band)	$P_{\min, NB}$	$B_{IF} = 30\text{kHz}$ , $\Delta f = \pm 5\text{kHz}$ , 4kbps NRZ, $BER \leq 3 \cdot 10^{-3}$ , 6)		-105		dBm
Input sensitivity – ASK	$P_{\min, ASK}$	$B_{IF} = 180\text{kHz}$ , 4kbps NRZ, $BER \leq 3 \cdot 10^{-3}$ , 6)		-109		dBm
Maximum input signal – FSK	$P_{\max, FSK}$	$BER \leq 3 \cdot 10^{-3}$ GAIN_LNA = 1		0		dBm
Maximum input signal – ASK	$P_{\max, ASK}$	$BER \leq 3 \cdot 10^{-3}$ GAIN_LNA = 1		-10		dBm
Spurious emission	$P_{\text{spur}}$				-70	dBm
Image rejection	$\Delta P_{\text{imag}}$			60		dB
<b>Start-up Parameters</b>						
Crystal start-up time	$T_{XTL}$	ENRX from 0 to 1			0.9	ms
Receiver start-up time	$T_{RX}$	ENRX from 0 to 1, depends on data slicer time constant, valid data at output			$T_{XTL}$ + $R4 \cdot C17$	
<b>PLL Parameters</b>						
VCO gain	$K_{VCO}$			350		MHz/V
Charge pump current	$I_{CP}$			60		$\mu\text{A}$

6) incl. 3 dB loss of front-end SAW filter

## 4 Test Circuits

### 4.1 Standard FSK Reception

#### 4.1.1 Standard FSK Application Circuit

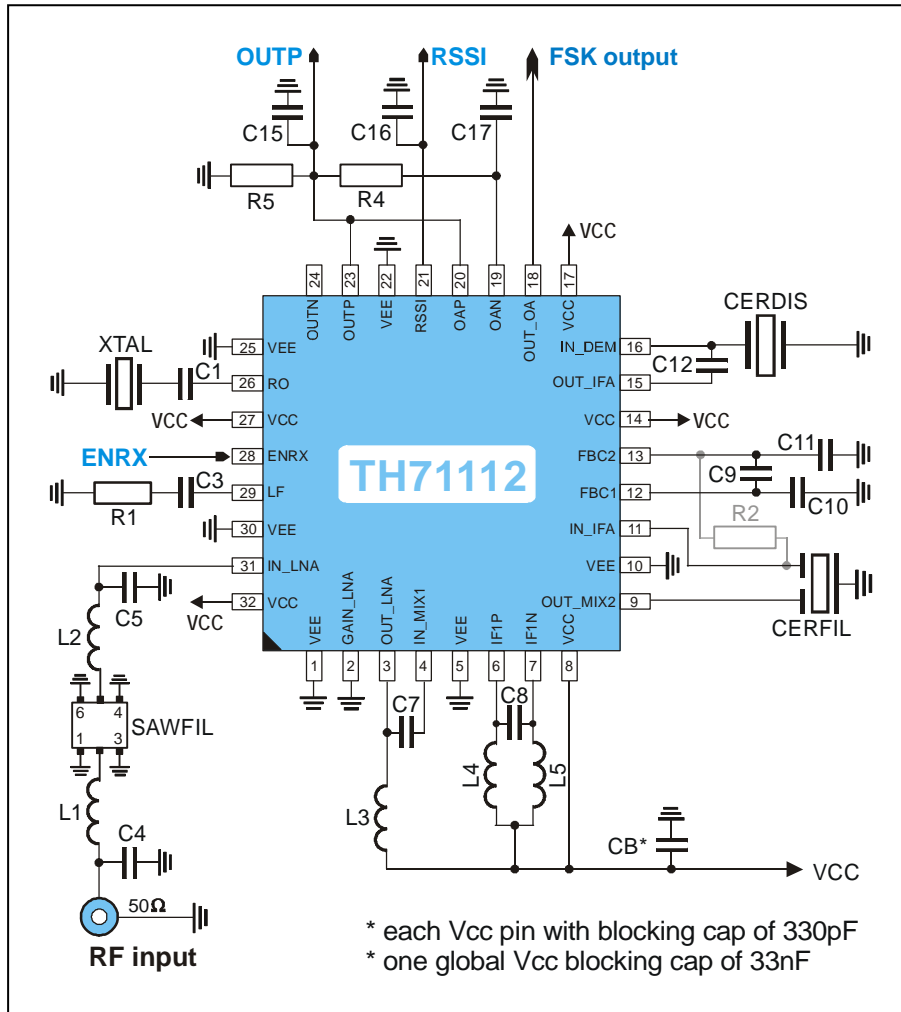

Fig. 2: Test circuit for FSK reception

### Circuit Features

- Tolerates input frequency variations
- Well-suited for NRZ, Manchester and similar codes

### 4.1.2 Standard FSK Component List

Part	Size	Value @ 868.3 MHz	Tolerance	Description
C1	0805	22 pF	±5%	crystal series capacitor
C3	0603	1 nF	±10%	loop filter capacitor
C4	0603	4.7 pF	±5%	capacitor to match SAW filter input
C5	0603	2.7 pF	±5%	capacitor to match SAW filter output
C7	0603	1.0 pF	±5%	MIX1 input matching capacitor
C8	0603	22 pF	±5%	IF1 tank capacitor
C9	0603	33 nF	±10%	IFA feedback capacitor
C10	0603	1 nF	±10%	IFA feedback capacitor
C11	0603	1 nF	±10%	IFA feedback capacitor
C12	0805	10 pF	±5%	DEMODO phase-shift capacitor
C15	0805	100 pF	±5%	demodulator output low-pass capacitor, this value for data rates < 20 kbps NRZ
C16	0805	1.5 nF	±10%	RSSI output low-pass capacitor
C17	0805	10 nF	±10%	data slicer capacitor, this value for data rates > 0.8 kbps NRZ
R1	0603	10 kΩ	±5%	loop filter resistor
R2	0603	330 Ω	±5%	optional CERFIL output matching resistor
R4	0805	330 kΩ	±5%	data slicer resistor
R5	0805	220 kΩ	±5%	loading resistor
L1	0603	22 nH	±5%	SAW filter matching inductor from Würth-Elektronik (WE-KI series), or equivalent part
L2	0603	22 nH	±5%	
L3	0603	10 nH	±5%	LNA output tank inductor from Würth-Elektronik (WE-KI series), or equivalent part
L4	0805	100 nH	±5%	IF1 tank inductor from Würth-Elektronik (WE-KI series) or equivalent part
L5	0805	100 nH	±5%	
XTAL	SMD 6x3.5	25.22353 MHz @ RF = 868.3 MHz	±25ppm cal. ±30ppm temp.	fundamental-mode crystal from Telcona/Horizon or equivalent part
SAWFIL	SMD 3x3	SAFCC868MSL0X00 (f <sub>0</sub> = 868.3 MHz)	B <sub>3dB</sub> = 2 MHz	low-loss SAW filter from Murata, or equivalent part
CERFIL	SMD 3.45x3.1	SFECF10M7HA00	B <sub>3dB</sub> = 180 kHz	ceramic filter from Murata, or equivalent part
CERDIS	SMD 4.5x2	CDSCB10M7GA135		ceramic discriminator from Murata, or equivalent part

- For component values for other frequencies, please refer to the EVB descriptions

## 4.2 Narrow Band FSK Reception

### 4.2.1 Narrow Band FSK Application Circuit

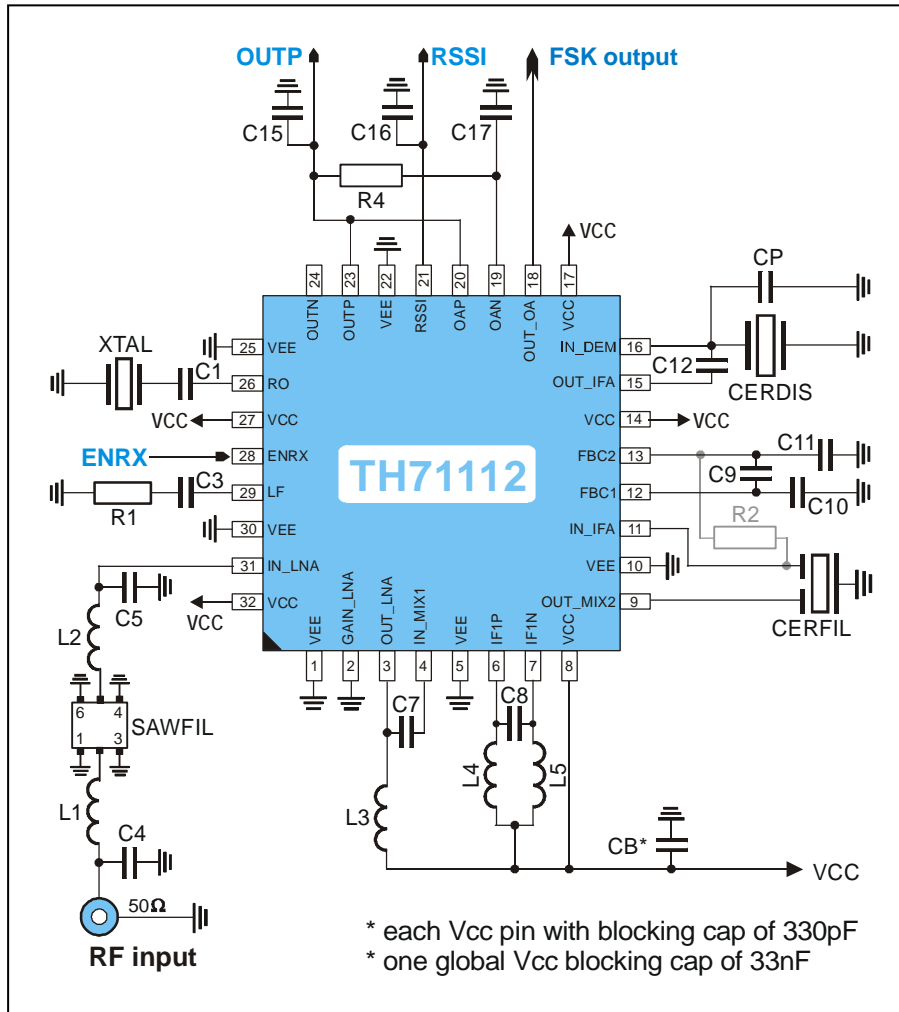

Fig. 3: Test circuit for FSK reception (narrow band)

### Circuit Features

- Applicable for narrow band FSK

## 4.2.2 Narrow Band FSK Component List

Part	Size	Value @ 868.3 MHz	Tolerance	Description
C1	0805	22 pF	±5%	crystal series capacitor
C3	0603	1 nF	±10%	loop filter capacitor
C4	0603	4.7 pF	±5%	capacitor to match SAW filter input
C5	0603	2.7 pF	±5%	capacitor to match SAW filter output
C7	0603	1.0 pF	±5%	MIX1 input matching capacitor
C8	0603	22 pF	±5%	IF1 tank capacitor
C9	0603	33 nF	±10%	IFA feedback capacitor
C10	0603	1 nF	±10%	IFA feedback capacitor
C11	0603	1 nF	±10%	IFA feedback capacitor
C12	0805	1.5 pF	±5%	DEMODO phase-shift capacitor
C15	0805	220 pF	±5%	demodulator output low-pass capacitor, this value for data rates < 10 kbps NRZ
C16	0805	1.5 nF	±10%	RSSI output low-pass capacitor
C17	0805	10 nF	±10%	data slicer capacitor, this value for data rates > 0.8 kbps NRZ
CP	0603	6.8 - 8.2 pF	±5%	ceramic resonator loading capacitor
R1	0603	10 kΩ	±5%	loop filter resistor
R2	0603	330 Ω	±5%	optional CERFIL output matching resistor
R4	0805	330 kΩ	±5%	data slicer resistor, this value for 0.4 to 10 kbps NRZ
L1	0603	22 nH	±5%	SAW filter matching inductor from Würth-Elektronik (WE-KI series), or equivalent part
L2	0603	22 nH	±5%	
L3	0603	10 nH	±5%	
L4	0805	100 nH	±5%	IF1 tank inductor from Würth-Elektronik (WE-KI series) or equivalent part
L5	0805	100 nH	±5%	
XTAL	SMD 6x3.5	25.22353 MHz @ RF = 868.3 MHz	±25ppm cal. ±30ppm temp.	fundamental-mode crystal from Telcona/Horizon or equivalent part
SAWFIL	SMD 3x3	SAFCC868MSL0X00 (f <sub>0</sub> = 868.3 MHz)	B <sub>3dB</sub> = 2 MHz	low-loss SAW filter from Murata, or equivalent part
CERFIL	Leaded type	SFKLA10M7NL00	B <sub>3dB</sub> = 30 kHz	ceramic filter from Murata, or equivalent part
		SFVLA10M7LF00	B <sub>3dB</sub> = 80 kHz	optional, ceramic filter from Murata, or equivalent part
CERDIS	SMD 4.5x2	CDSCB10M7GA135		ceramic discriminator from Murata, or equivalent part

- For component values for other frequencies, please refer to the EVB descriptions

**4.3 ASK Reception**

**4.3.1 ASK Application Circuit**

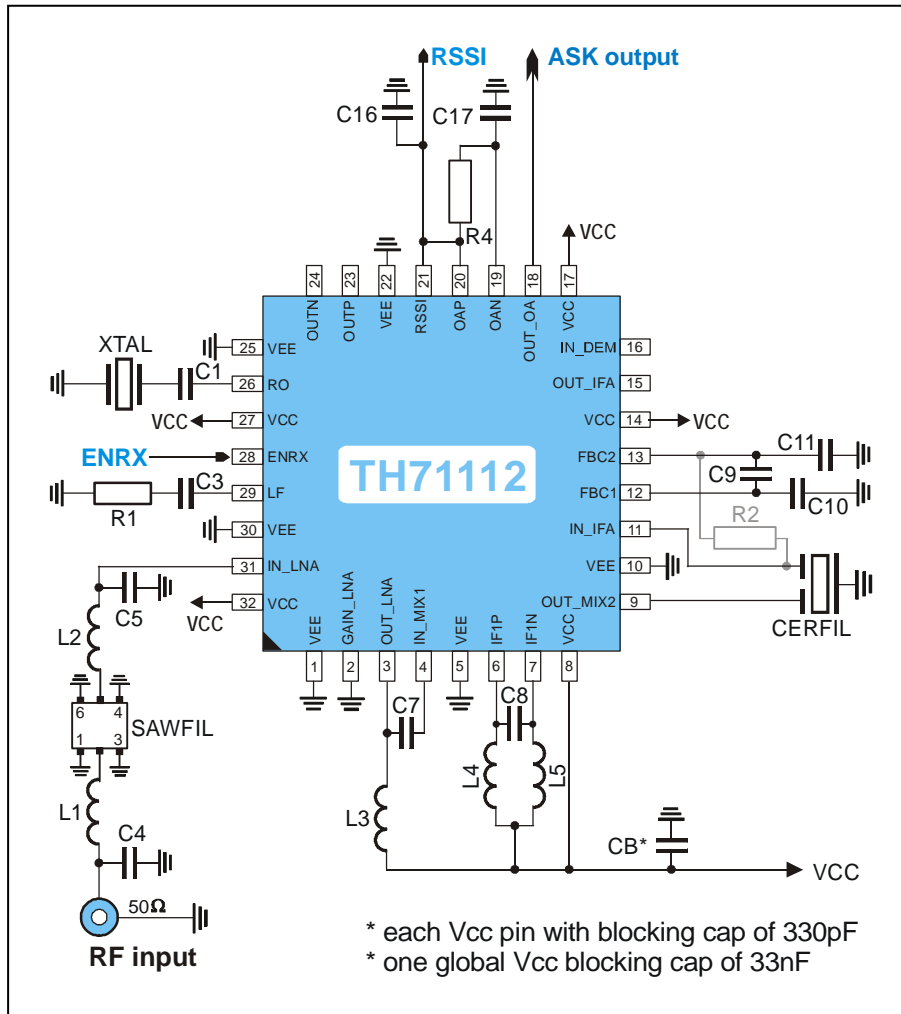



Fig. 4: Test circuit for ASK reception

### 4.3.2 ASK Component List

Part	Size	Value @ 868.3 MHz	Tolerance	Description
C1	0805	22 pF	±5%	crystal series capacitor
C3	0603	1 nF	±10%	loop filter capacitor
C4	0603	4.7 pF	±5%	capacitor to match SAW filter input
C5	0603	2.7 pF	±5%	capacitor to match SAW filter output
C7	0603	1.0 pF	±5%	MIX1 input matching capacitor
C8	0603	22 pF	±5%	IF1 tank capacitor
C9	0603	33 nF	±10%	IFA feedback capacitor
C10	0603	1 nF	±10%	IFA feedback capacitor
C11	0603	1 nF	±10%	IFA feedback capacitor
C16	0805	1.5 nF	±10%	RSSI output low-pass capacitor, this value for data rates < 10 kbps NRZ, for higher data rates decrease the value
C17	0805	10 nF	±10%	data slicer capacitor, this value for data rates > 0.8 kbps NRZ, for lower data rates increase the value
R1	0603	10 kΩ	±5%	loop filter resistor
R2	0603	330 Ω	±5%	optional CERFIL output matching resistor
R4	0805	330 kΩ	±5%	data slicer resistor
L1	0603	22 nH	±5%	SAW filter matching inductor from Würth-Elektronik (WE-KI series), or equivalent part
L2	0603	22 nH	±5%	
L3	0603	10 nH	±5%	LNA output tank inductor from Würth-Elektronik (WE-KI series), or equivalent part
L4	0805	100 nH	±5%	IF1 tank inductor from Würth-Elektronik (WE-KI series) or equivalent part
L5	0805	100 nH	±5%	
XTAL	SMD 6x3.5	25.22353 MHz @ RF = 868.3 MHz	±25ppm cal. ±30ppm temp.	fundamental-mode crystal from Telcona/Horizon or equivalent part
SAWFIL	SMD 3x3	SAFCC868MSL0X00 (f <sub>0</sub> = 868.3 MHz)	B <sub>3dB</sub> = 2 MHz	low-loss SAW filter from Murata, or equivalent part
CERFIL	SMD 3.45x3.1	SFECF10M7HA00	B <sub>3dB</sub> = 180 kHz	ceramic filter from Murata, or equivalent part
	Leaded type	SFVLA10M7LF00	B <sub>3dB</sub> = 80 kHz	optional, ceramic filter from Murata, or equivalent part

- For component values for other frequencies, please refer to the EVB descriptions

## 5 Package Description

 The device TH71112 is RoHS compliant.

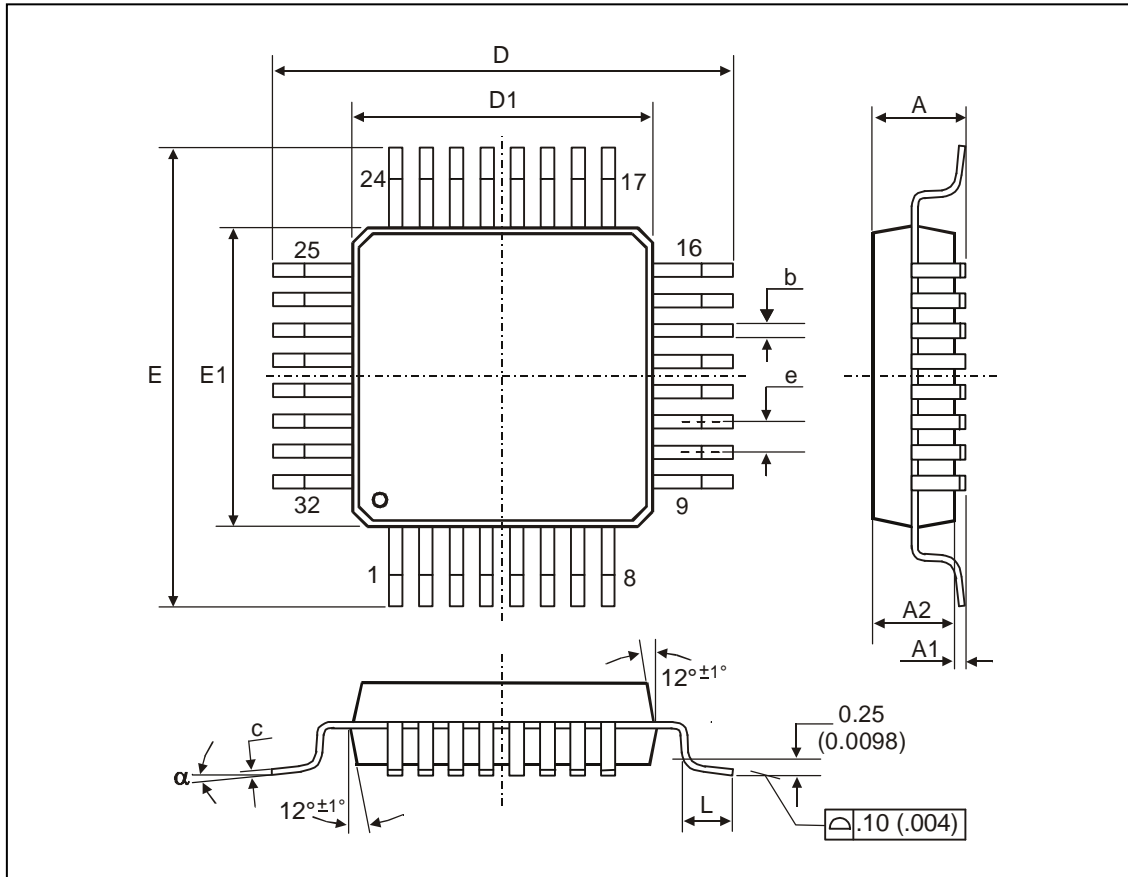

Fig. 6: LQFP32 (Low profile Quad Flat Package)

All Dimension in mm, coplanarity < 0.1mm										
	E1, D1	E, D	A	A1	A2	e	b	c	L	$\alpha$
min	7.00	9.00	1.40	0.05	1.35	0.8	0.30	0.09	0.45	0°
max			1.60	0.15	1.45		0.45	0.20	0.75	7°
All Dimension in inch, coplanarity < 0.004"										
min	0.276	0.354	0.055	0.002	0.053	0.031	0.012	0.0035	0.018	0°
max			0.063	0.006	0.057		0.018	0.0079	0.030	7°

### 5.1 Soldering Information

- The device TH71112 is qualified for MSL3 with soldering peak temperature 260 deg C according to JEDEC J-STD-20

## **6 Reliability Information**

This Melexis device is classified and qualified regarding soldering technology, solderability and moisture sensitivity level, as defined in this specification, according to following test methods:

### **Reflow Soldering SMD's (Surface Mount Devices)**

- IPC/JEDEC J-STD-020  
"Moisture/Reflow Sensitivity Classification for Nonhermetic Solid State Surface Mount Devices (classification reflow profiles according to table 5-2)"

### **Wave Soldering SMD's (Surface Mount Devices)**

- EN60749-20  
"Resistance of plastic- encapsulated SMD's to combined effect of moisture and soldering heat"

### **Solderability SMD's (Surface Mount Devices)**

- EIA/JEDEC JESD22-B102  
"Solderability"

For all soldering technologies deviating from above mentioned standard conditions (regarding peak temperature, temperature gradient, temperature profile etc) additional classification and qualification tests have to be agreed upon with Melexis.

The application of Wave Soldering for SMD's is allowed only after consulting Melexis regarding assurance of adhesive strength between device and board.

## **7 ESD Precautions**

Electronic semiconductor products are sensitive to Electro Static Discharge (ESD). Always observe Electro Static Discharge control procedures whenever handling semiconductor products.

## 8 Disclaimer

- 1) The information included in this documentation is subject to Melexis intellectual and other property rights. Reproduction of information is permissible only if the information will not be altered and is accompanied by all associated conditions, limitations and notices.
  - 2) Any use of the documentation without the prior written consent of Melexis other than the one set forth in clause 1 is an unfair and deceptive business practice. Melexis is not responsible or liable for such altered documentation.
  - 3) The information furnished by Melexis in this documentation is provided 'as is'. Except as expressly warranted in any other applicable license agreement, Melexis disclaims all warranties either express, implied, statutory or otherwise including but not limited to the merchantability, fitness for a particular purpose, title and non-infringement with regard to the content of this documentation.
  - 4) Notwithstanding the fact that Melexis endeavors to take care of the concept and content of this documentation, it may include technical or factual inaccuracies or typographical errors. Melexis disclaims any responsibility in connection herewith.
  - 5) Melexis reserves the right to change the documentation, the specifications and prices at any time and without notice. Therefore, prior to designing this product into a system, it is necessary to check with Melexis for current information.
  - 6) Melexis shall not be liable to recipient or any third party for any damages, including but not limited to personal injury, property damage, loss of profits, loss of use, interrupt of business or indirect, special incidental or consequential damages, of any kind, in connection with or arising out of the furnishing, performance or use of the information in this documentation.
  - 7) The product described in this documentation is intended for use in normal commercial applications. Applications requiring operation beyond ranges specified in this documentation, unusual environmental requirements, or high reliability applications, such as military, medical life-support or life-sustaining equipment are specifically not recommended without additional processing by Melexis for each application.
  - 8) Any supply of products by Melexis will be governed by the Melexis Terms of Sale, published on [www.melexis.com](http://www.melexis.com).
- © Melexis NV. All rights reserved.

---

For the latest version of this document, go to our website at:

[www.melexis.com](http://www.melexis.com)

Or for additional information contact Melexis Direct:

Europe, Africa:  
Phone: +32 1367 0495  
E-mail: [sales\\_europe@melexis.com](mailto:sales_europe@melexis.com)

Americas:  
Phone: +1 603 223 2362  
E-mail: [sales\\_usa@melexis.com](mailto:sales_usa@melexis.com)

Asia:  
Phone: +32 1367 0495  
E-mail: [sales\\_asia@melexis.com](mailto:sales_asia@melexis.com)

ISO/TS 16949 and ISO14001 Certified