

Features and Benefits

- ❑ Low cost
- ❑ High sensitivity Hall Sensor
- ❑ Locked rotor protection and auto-restart
- ❑ Power-efficient CMOS and power MOSFETs
- ❑ Built-in output protection clamping diode
- ❑ Integrated tachometer (US62) or alarm (US63) signal protected output
- ❑ 2-coil fan driver with FG/RD output in 4-pin VK package RoHS Compliant

Application Examples

- ❑ 5/12V fans
- ❑ Peak current up to 700mA

Ordering Information

Part No.	Temperature Code	Package Code
US62	E (-40 °C to 85 °C)	VK (4-pin TO-92)
US63	E (-40 °C to 85 °C)	VK (4-pin TO-92)

1 Functional Diagram

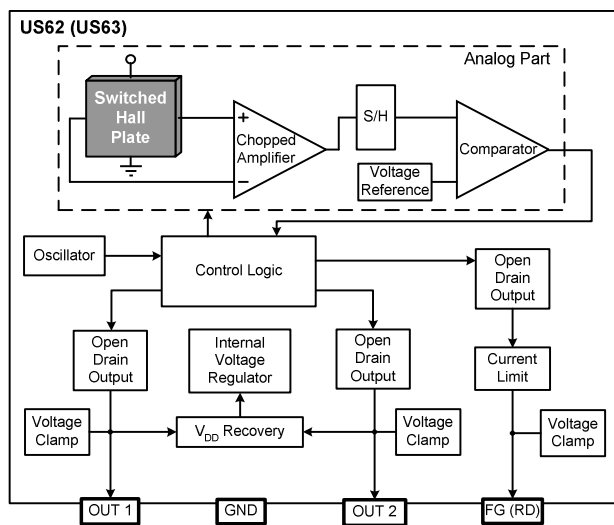

2 General Description

The US62/63 is a one-chip solution for driving two-coil brushless DC cooling fans.

Based on the advanced Melexis CMOS process, the IC contains a Hall-effect sensor, dynamic offset correction and low side output drivers.

Frequency Generator or Rotation Detection is available. The open-drain output makes easier the connectivity with any external interface such as hardware monitoring or Super I/O IC.

These features are combined with the Melexis patented no- V_{DD} design to fit the IC in a small 4-pin VK package.

Table of Contents

1 Functional Diagram 1

2 General Description 1

3 Glossary of Terms 3

4 Absolute Maximum Ratings 3

5 Pin Definitions and Descriptions 3

6 General Electrical Specifications 4

7 Magnetic Characteristics 4

8 Driver Output vs Magnetic Pole 4

9 Detailed General Description 5

10 Unique Features 5

11 Performance Graphs 6

 11.1 $R_{DS(on)}$ vs T_J 6

 11.2 $R_{DS(on)}$ vs V_{DD} 6

 11.3 Magnetic Parameters vs T_J 6

 11.4 Magnetic Parameters vs V_{DD} 6

 11.5 I_{DD} vs V_{DD} 6

12 Test conditions 7

 12.1 V_{DD} – operating 7

 12.2 $R_{DS(on)}$ 7

 12.3 I_{DD} 7

 12.4 FG/RD Output Low Voltage 7

13 Application Information 8

 13.1 Typical application with pull-up resistor 8

 13.2 Configuration for reverse voltage / ground hot-switch protection 8

14 Application Comments 8

15 Standard information regarding manufacturability of Melexis products with different soldering processes 9

16 ESD Precautions 9

17 VK Package Information (4-pin TO-92) 10

18 Disclaimer 11

3 Glossary of Terms

Two-coil fan	A fan with two-coil windings where current alternates from 1 coil to the other depending on the direction of the magnetic field.
MilliTesla (mT), Gauss	Units of magnetic flux density : 1mT = 10 Gauss
V _{DD}	Voltage on the common point of the fan coils.
I _{DD}	Current supplying the chip which flows through the coil connected to the switched off output driver.
Peak output current	The current flowing in the coil at start-up, only limited by the coil resistance R _{COIL} and the output driver resistance R _{DSON} .
Continuous output current	The current flowing in the coil when the fan is spinning normally.
Locked rotor	The state when the fan stopped spinning due to mechanical blockage.
FG	Frequency generator or tachometer output
RD	Rotation detection or alarm output
LFPM	Linear Feet Per Minute – Unit of airflow velocity

4 Absolute Maximum Ratings

Parameter	Symbol	Value	Units
Fan Supply Voltage	V _{DD}	18	V
Peak Output Current	I _{OUTp}	700	mA
Continuous Output Current	I _{OUTc}	250	mA
Operating Temperature Range	T _A	-40 to 85	°C
Junction Temperature	T _J	125	°C
Storage Temperature Range	T _S	-55 to 150	°C
Magnetic Flux Density	B	Unlimited	mT
ESD Sensitivity (AEC Q100 002)	-	2	kV

Table 1: Absolute maximum ratings

Exceeding the absolute maximum ratings may cause permanent damage. Exposure to absolute-maximum-rated conditions for extended periods may affect device reliability.

5 Pin Definitions and Descriptions



Pin Name	Pin number	Function
FG (RD)	1	Frequency Generator (Rotation Detection) open drain output signal
OUT1	2	Open Drain Coil Driver 1
OUT2	3	Open Drain Coil Driver 2
GND	4	Ground pin

Table 2: Pin definitions and descriptions US62 (US63)

6 General Electrical Specifications

DC Operating Parameters $T_A = 25^\circ\text{C}$, $V_{DD} = 5\text{V}$ to 12V (unless otherwise specified)

Parameter	Symbol	Test Conditions	Min	Typ	Max	Units
Fan Supply Voltage	V_{DD}	Operating – $R_{COIL} = 50\Omega$	3.2 ⁽¹⁾		18	V
Supply Current	I_{DD}			2	4	mA
OUT1, OUT2 ON Resistance	$R_{DSON\ 1,2}$	$V_{DD} = 5\text{V}$		3.5		Ω
OUT1, OUT2 ON Resistance	$R_{DSON\ 1,2}$	$V_{DD} = 12\text{V}$		2.5		Ω
OUT1, OUT2 Output Clamp Voltage	$V_{OUT1,2}$		36			V
FG / RD Output Low Voltage	V_{OL}	$I_{OL} = 10\text{mA}$		250	500	mV
FG / RD Output Clamp Voltage	V_{CLMP}		18			V
FG / RD Output Leakage Current	I_{LEAK}	$V_{FG}(V_{RD}) = 18\text{V}$			10	μA
FG / RD Output Current Limit	I_{FGLIM}	$V_{FG}(V_{RD}) = 12\text{V}$		20		mA
Package Thermal Resistance	R_{TH}	One-sided PCB, zero LFPM		200		$^\circ\text{C}/\text{Watt}$
Locked Rotor Period	T_{ON}			0.22		S
Locked Rotor Period	T_{OFF}			1.3		S
Output Switching Delay	T_{DELAY}	“Dead time” when both drivers are off		100		μs

Table 3: Electrical specifications

Note 1: The minimal value of V_{DD} should be determined using the following equation:

$$V_{DD} = 3\text{V} + R_{COIL} * I_{DD}$$

7 Magnetic Characteristics

DC Operating Parameters $T_A = 25^\circ\text{C}$, $V_{DD} = 12\text{V}$ (unless otherwise specified)

Parameter	Symbol	Test Conditions	Min	Typ	Max	Units
Operate point	B_{OP}			3	6	mT
Release point	B_{RP}		-6	-3		mT
Hysteresis	B_{HYST}		2	6		mT

Table 4: Magnetic specifications

8 Driver Output vs Magnetic Pole

Parameter	Test Conditions	OUT1	OUT2
North pole	$B < B_{RP}$	High	Low
South pole	$B > B_{OP}$	Low	High

Table 5: Driver output vs magnetic pole

Note 1: The magnetic pole is applied facing the branded side of the package

9 Detailed General Description

The US62/63 is a one-chip solution for driving two-coil brushless DC fans. Based on advanced Melexis CMOS process, the IC contains a Hall-effect sensor, dynamic offset correction and low side output drivers.

The output drivers OUT1 and OUT2 are fully protected against switching transients. So there is no need for an external zener diode to cut the high voltage spikes induced by the fan coils.

The US62 has an open-drain integrated tachometer FG output that follows the Hall signal. In the US63, the open-drain rotation detection output RD is active low during normal spinning of the motor. It goes high when the flux switching frequency becomes too low, which means the motor is blocked.

10 Unique Features

The FG/RD output driver provides an over current protection limiting the current flowing in the FG/RD driver while switched ON. It can occur if a too small pull-up resistor is used or if this resistor is short connected. This protection helps avoid EOS damage on the FG/RD driver.

The absence of a V_{DD} pin enables the two low side output drivers and FG/RD signal output to fit in a four-pin VK package. The lack of a V_{DD} pin decreases also the probability to damage the chip due to reverse voltage connection, using the coil resistance to limit the reverse current. In this condition, the total reverse current is twice the peak current value of the fan used.

The built-in locked-rotor protection automatically shuts off the coil current when the rotor is mechanically blocked, or the rotational speed becomes too low. The fan tries to restart every 1.3 seconds until the rotation of the shaft is allowed again. The On / Off cycling reduces the average current to 1/7 normal. It is enough to prevent overheating or damage to most fans.

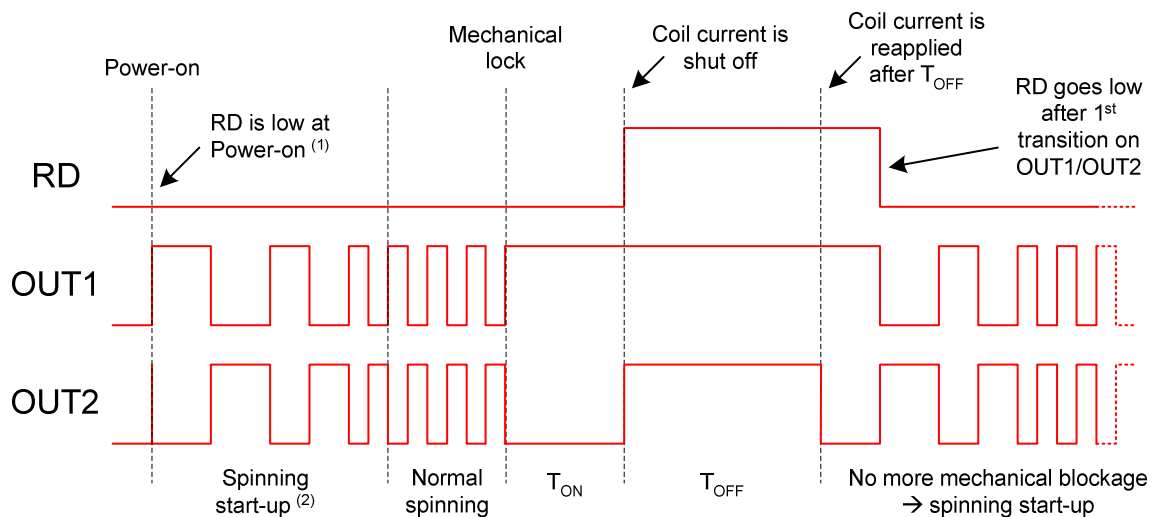

Note 1 : At Power-on, RD is low. If no transition occurs on OUT1/OUT2 before T_{ON} time, RD goes high.

Note 2 : The spinning start-up is the ramp between the zero speed and maximal speed. It depends on the motor characteristics.

Note 3 : This graph does not represent the EMF effect.

11 Performance Graphs

11.1 R_{DSON} vs T_J

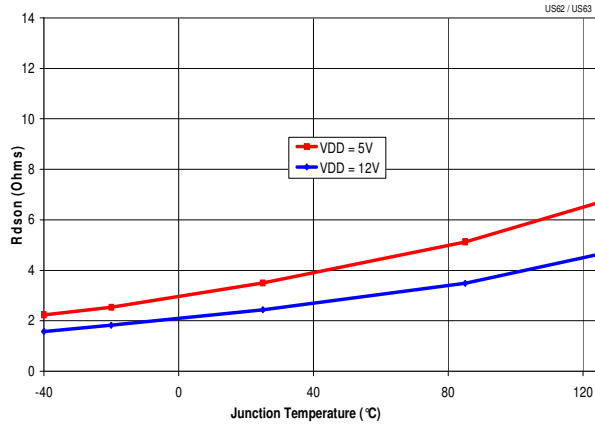

11.2 R_{DSON} vs V_{DD}

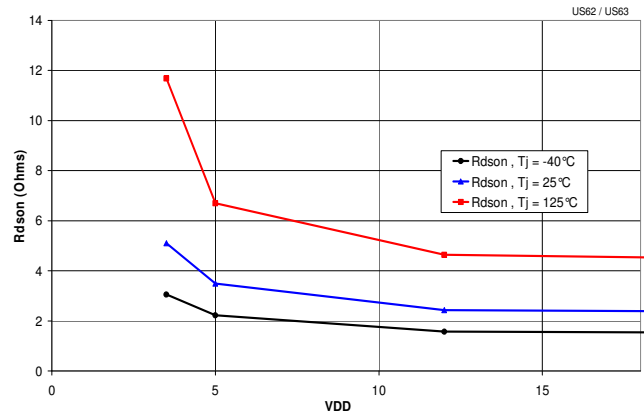

11.3 Magnetic Parameters vs T_J

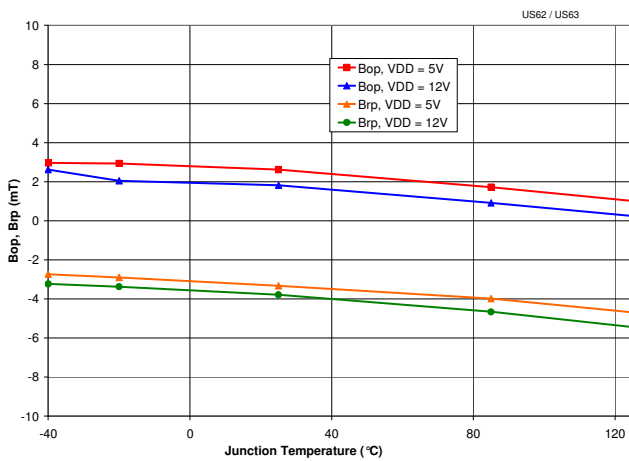

11.4 Magnetic Parameters vs V_{DD}

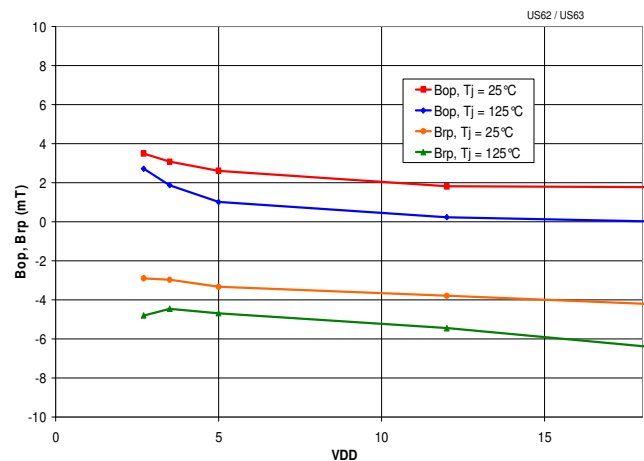

11.5 I_{DD} vs V_{DD}

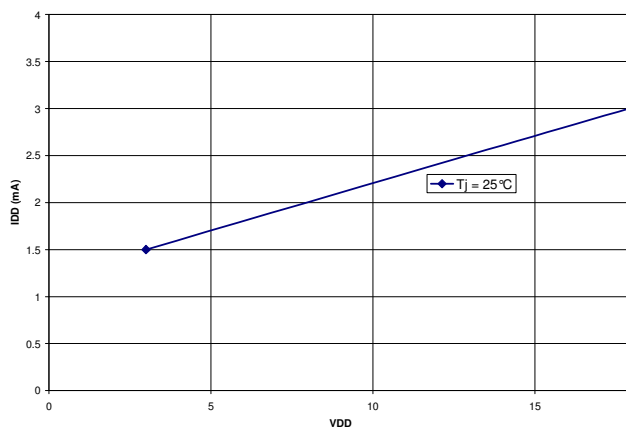

12 Test conditions

12.1 V_{DD} – operating

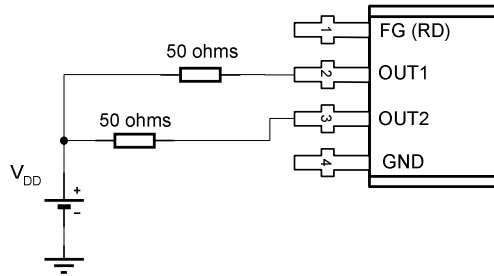

Note 1 - "Operating" states the condition when all the chip functions are working normally

12.2 R_{DSON}

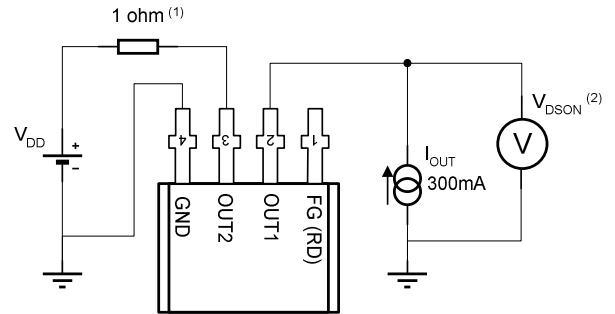

Note 1 - The chip is triggered to have OUT2 = high and OUT1 = low. A small resistor value is used to have V_{DD} equal to V_{OUT2}

Note 2 - The output driver resistance R_{DSON} is calculated via the relation:
 $R_{DSON} = V_{DSON} / I_{OUT}$

12.3 I_{DD}

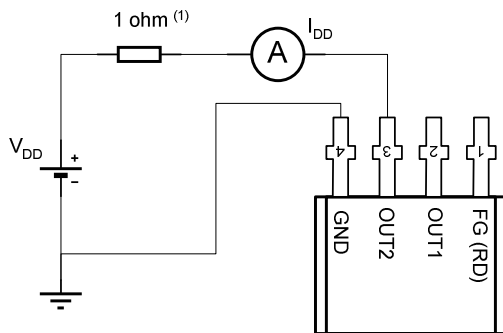

Note 1 - The chip is triggered to have OUT2 = high and OUT1 = low. A small resistor value is used to have V_{DD} equal to V_{OUT2}

12.4 FG/RD Output Low Voltage

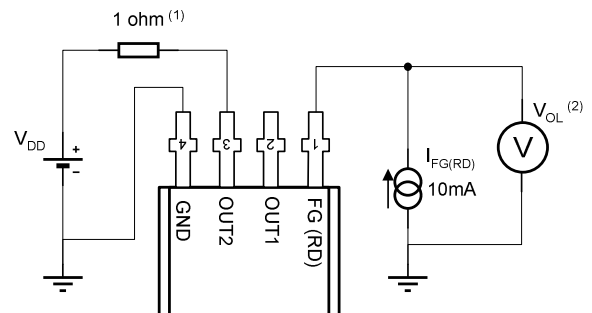

Note 1 - The chip is triggered to have OUT2 = high and OUT1 = low. A small resistor value is used to have V_{DD} equal to V_{OUT2}

Note 2 - The FG/RD output low voltage is measured during the first T_{ON} period at the power-on event.

13 Application Information

13.1 Typical application with pull-up resistor

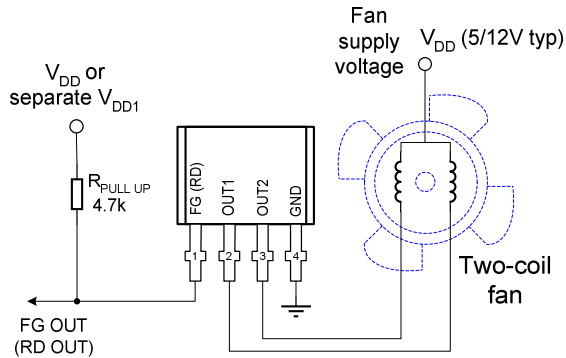

13.2 Configuration for reverse voltage / ground hot-switch protection

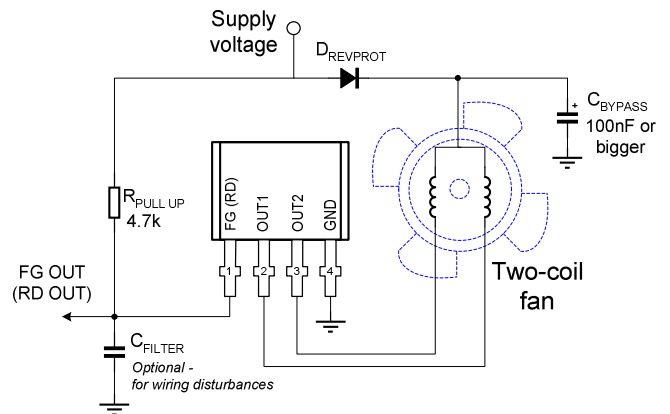

14 Application Comments

Figure 13.2 shows the application including several external protections.

The diode $D_{REVPROT}$ best protects the chip and fan coils for reverse voltage condition.

The capacitor C_{BYPASS} is recommended if the supply ground may be disconnected while running even though the positive supply point is still connected. This capacitor provides a path to ground for the remaining energy in the coil which has to be evacuated. Without it, the energy can flow from OUT1/OUT2 to the FG/RD driver, without any limitation and may cause EOS damage.

Its value has to be tuned depending on the coils characteristics. Bigger inductance requires bigger capacitor.

The optional capacitor C_{FILTER} suppresses wire disturbances on the FG/RD output line.

15 Standard information regarding manufacturability of Melexis products with different soldering processes

Our products are classified and qualified regarding soldering technology, solderability and moisture sensitivity level according to following test methods:

Reflow Soldering SMD's (Surface Mount Devices)

- IPC/JEDEC J-STD-020
Moisture/Reflow Sensitivity Classification for Nonhermetic Solid State Surface Mount Devices (classification reflow profiles according to table 5-2)
- EIA/JEDEC JESD22-A113
Preconditioning of Nonhermetic Surface Mount Devices Prior to Reliability Testing (reflow profiles according to table 2)
- Melexis Working Instruction 341901308

Wave Soldering SMD's (Surface Mount Devices) and THD's (Through Hole Devices)

- EN60749-20
Resistance of plastic- encapsulated SMD's to combined effect of moisture and soldering heat
- EIA/JEDEC JESD22-B106 and EN60749-15
Resistance to soldering temperature for through-hole mounted devices
- Melexis Working Instruction 341901309

Iron Soldering THD's (Through Hole Devices)

- EN60749-15
Resistance to soldering temperature for through-hole mounted devices
- Melexis Working Instruction 341901309

Solderability SMD's (Surface Mount Devices) and THD's (Through Hole Devices)

- EIA/JEDEC JESD22-B102 and EN60749-21
Solderability
- Melexis Working Instruction 3304312

For all soldering technologies deviating from above mentioned standard conditions (regarding peak temperature, temperature gradient, temperature profile etc) additional classification and qualification tests have to be agreed upon with Melexis.

The application of Wave Soldering for SMD's is allowed only after consulting Melexis regarding assurance of adhesive strength between device and board.

For more information on the lead free topic please see quality page at our website:
<http://www.melexis.com/quality.asp>

16 ESD Precautions

Electronic semiconductor products are sensitive to Electro Static Discharge (ESD). Always observe Electro Static Discharge control procedures whenever handling semiconductor products.

17 VK Package Information (4-pin TO-92)

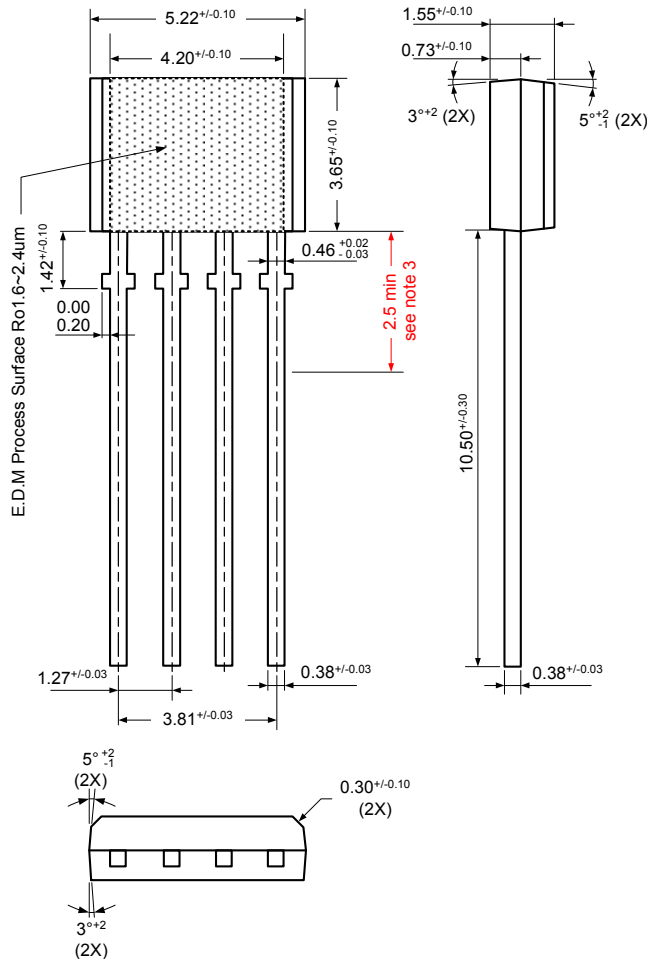

Notes:

1. All dimensions are in millimeters
2. Package dimension exclude molding flash. Mold flash shall not exceed 0.127mm.
3. To preserve reliability, it is recommended to have total lead length equal to 2.5mm minimum, measured from the package line.
4. VK package is a pin through-hole package, hence adapted for wave soldering process. A reflow soldering process is not recommended with VK package as it may seriously affect device reliability.

Marking:

- 1st Line : US62 (US63) - Name of the device
 2nd Line : xxxxx - the last 5 digits of lot number

Hall plate location

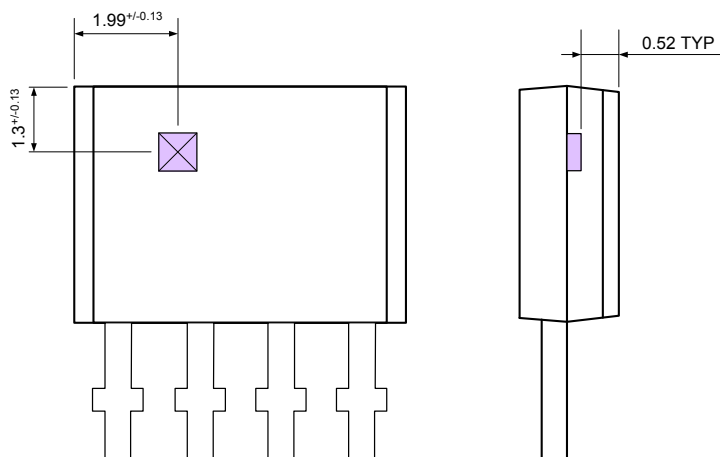

Notes:

1. All dimensions are in millimeters

18 Disclaimer

Devices sold by Melexis are covered by the warranty and patent indemnification provisions appearing in its Term of Sale. Melexis makes no warranty, express, statutory, implied, or by description regarding the information set forth herein or regarding the freedom of the described devices from patent infringement. Melexis reserves the right to change specifications and prices at any time and without notice. Therefore, prior to designing this product into a system, it is necessary to check with Melexis for current information. This product is intended for use in normal commercial applications. Applications requiring extended temperature range, unusual environmental requirements, or high reliability applications, such as military, medical life-support or life-sustaining equipment are specifically not recommended without additional processing by Melexis for each application.

The information furnished by Melexis is believed to be correct and accurate. However, Melexis shall not be liable to recipient or any third party for any damages, including but not limited to personal injury, property damage, loss of profits, loss of use, interrupt of business or indirect, special incidental or consequential damages, of any kind, in connection with or arising out of the furnishing, performance or use of the technical data herein. No obligation or liability to recipient or any third party shall arise or flow out of Melexis' rendering of technical or other services.

© 2002 Melexis NV. All rights reserved.

For the latest version of this document, go to our website at
www.melexis.com

Or for additional information contact Melexis Direct:

Europe and Japan:
Phone: +32 1367 0495
E-mail: sales_europe@melexis.com

All other locations:
Phone: +1 603 223 2362
E-mail: sales_usa@melexis.com

ISO/TS 16949 and ISO14001 Certified