

1. Scope

This document describes the design and use of the MLX10803 mini evaluation board. For a general description about the functionality of the MLX10803 please refer to the MLX10803 data sheet.

2. Application

The MLX10803 mini evaluation board is intended to be used as an application example of the MLX10803 Power LED driver. It was developed to demonstrate the principal features of the circuit and is optimized and fixed for a single LED that is driven at 700mA average current. The circuit functions in a wide supply range of 6-32V and is reverse polarity protected.

For users who want to explore the advanced features (like PWM, temperature regulation etc.) of the chip we recommend using the standard evaluation board EVB10803. Please consult the MLX10803 internet product page at <http://www.melexis.com> for data sheets and latest updates.

3. Application Circuit

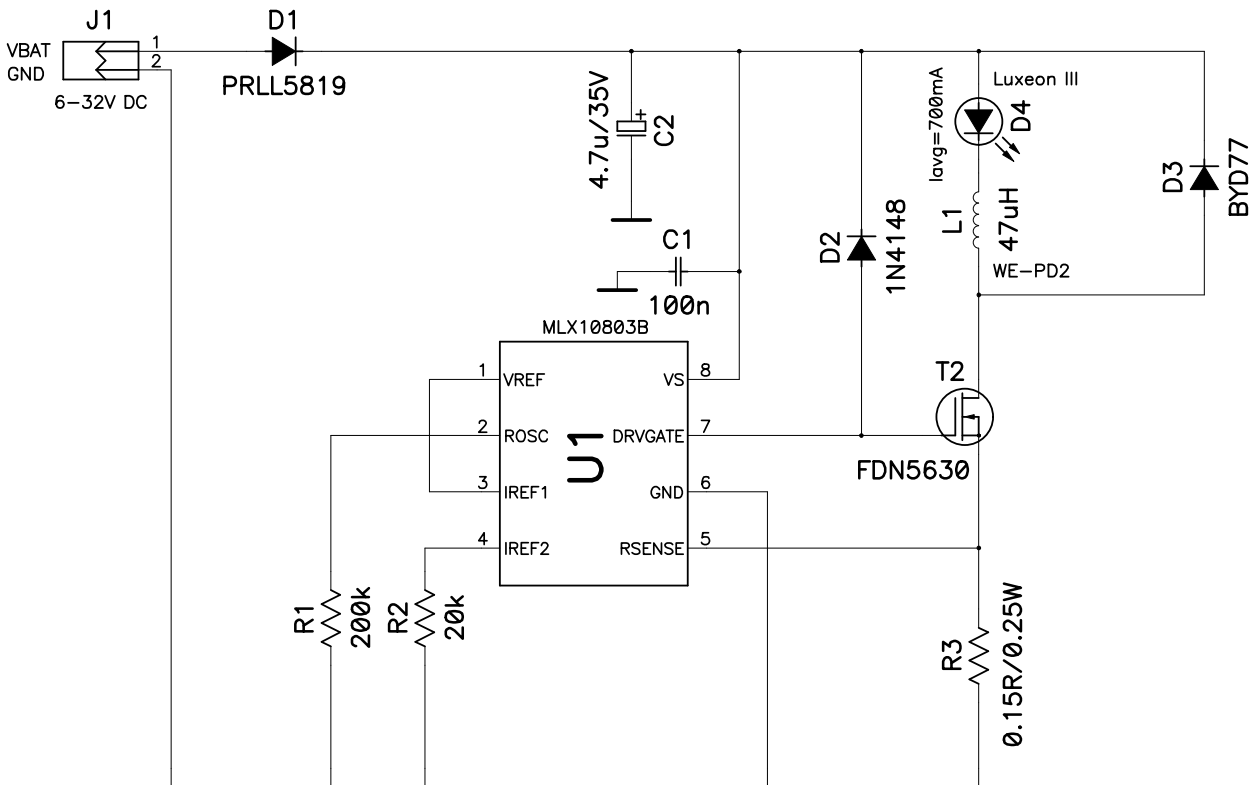

Figure 1: Evaluation board schematic

4. Connector Pin Definitions

Connector J1 (Supply)	Signal	Connection
Pin1	VBAT	General load and IC supply, 6..32V DC
Pin2	GND	Supply ground

5. PCB Layout

J1 Pinout (Supply)	
Pin1	VBAT
Pin2	GND

LED Pinout (D4)	
LED+	Anode
LED-	Cathode

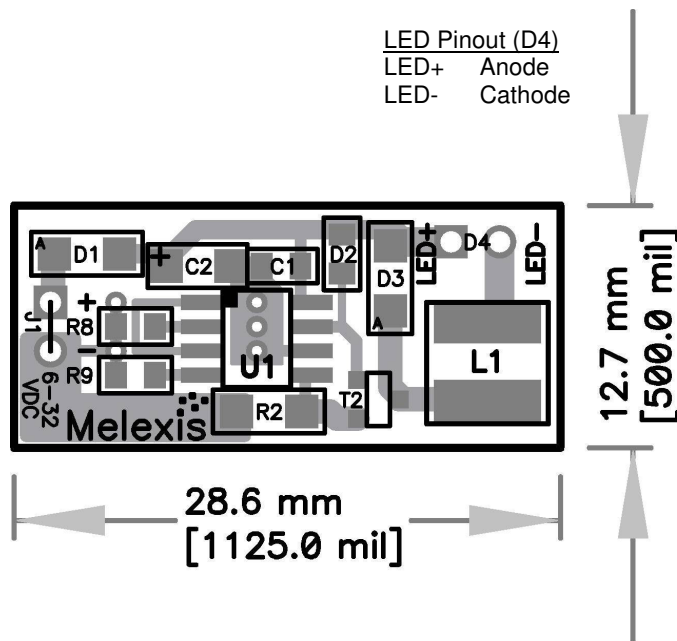

Figure 2: Evaluation board dimensions and locations

6. Board Connections

As the board is delivered together with a connected LED (Luxeon III) it has to be connected only to a supply. The connector J1 consists of both VBAT and GND terminations. Any standard DC supply with a nominal current of $\geq 1A$ can be used.

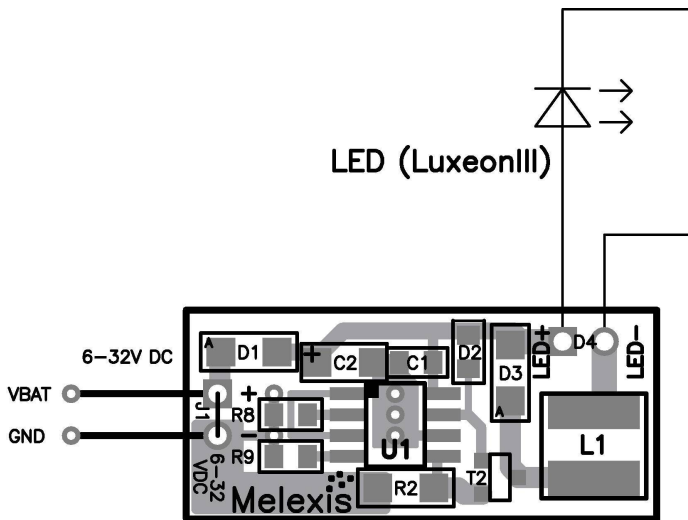

Figure 3: Connection to a DC supply

7. Circuit Description

For details on the function of the LED driver circuit, please refer to the MLX10803 IC specification.

The setting resistors R1 (ROSC) and R2 (IREF2) together with the sense resistor R3 mainly define the average current of the LED. R1 defined the drivers OFF (or monoflop) time while R2 in conjunction with the sense resistor R3 defines the peak current of the LED. The average current of the LED is determined by these 2 parameters.

For R1, a value of 200k was selected. We get:

$$R_{osc}[k\Omega] = 222.2 \cdot \frac{T_{mon}[\mu s]}{12.5} - 0.02 \quad (\text{equation according to MLX10803 datasheet, page 10})$$

$$T_{mon}[\mu s] = 12.5 \cdot \frac{R_{osc}[k\Omega] + 4.44}{222.2} = 12.5 \cdot \frac{200 + 4.44}{222.2}$$

$$T_{mon} = \underline{\underline{11.5 \mu s}}$$

The sense resistor R3 (0.15Ω) and the setting resistor R2 (20kΩ) of the MLX10803 were selected in order to set the maximum peak current of the LED. We get:

$$U_{IREF1} = I_{REF1} \cdot R2 = 50\mu A \cdot 20k\Omega = 1.00V$$

$$U_{THRESH_RSENSE} = U_{IREF1} \div 5 = 200mV$$

$$I_{MAX_RSENSE} = U_{THRESH_RSENSE} \div R3 = \underline{\underline{1.33A}}$$

With these both parameters, the LED current is set to an average current of about 700mA. This current is kept constant for the whole input range of VBAT= 6-32V.

8. Used Components

Board Part Number	Type	Category	Part Name (Manufacturer)	Data Sheet Download
D1	Rectifier	Schottky Diode	PRLL5819 (PHI)	www.semiconductor.philips.com
D3	Diode	Ultrafast Recovery	BYD77 (PHI)	www.semiconductor.philips.com www.fairchildsemiconductor.com
D2	Diode	Switching Diode	MCL4148	www.vishay.com
T1	Switching Transistor	n-channel MOSFET	FDN5630 (FCH)	www.fairchildsemiconductor.com
L1	Inductor	Power choke	WE-PD2 47μH (WE)	www.wuerth-elektronik.de
C1	Capacitor 100nF/50V	Ceramics, X7R, 0805 type	B37941 (EP)	www.epcos.com
C2	Capacitor 4.7μF/35V	Tantalum electrolytic, low ESR	TAJB475K035R (AVX)	www.avx.com
R1, R2	Resistors 5% tolerance	0805 type	D12CRCW (VS)	www.vishay.com
R3	Resistor 0.15Ω/0.5W 1% tolerance	1206 type	LR1206-R33FI (WW)	www.welwyn-tt.co.uk

manufacturer codes:

FCH = Fairchild Semiconductor
VS = Vishay
WW = Welwyn

PHI = Philips Semiconductor
EP = Epcos

WE = Würth Elektronik
AVX = AVX

Disclaimer

Devices sold by Melexis are covered by the warranty and patent indemnification provisions appearing in its Term of Sale. Melexis makes no warranty, express, statutory, implied, or by description regarding the information set forth herein or regarding the freedom of the described devices from patent infringement. Melexis reserves the right to change specifications and prices at any time and without notice. Therefore, prior to designing this product into a system, it is necessary to check with Melexis for current information. This product is intended for use in normal commercial applications. Applications requiring extended temperature range, unusual environmental requirements, or high reliability applications, such as military, medical life-support or life-sustaining equipment are specifically not recommended without additional processing by Melexis for each application.

The information furnished by Melexis is believed to be correct and accurate. However, Melexis shall not be liable to recipient or any third party for any damages, including but not limited to personal injury, property damage, loss of profits, loss of use, interrupt of business or indirect, special incidental or consequential damages, of any kind, in connection with or arising out of the furnishing, performance or use of the technical data herein. No obligation or liability to recipient or any third party shall arise or flow out of Melexis' rendering of technical or other services.

© 2002 Melexis NV. All rights reserved.

For the latest version of this document, go to our website at:

www.melexis.com

Or for additional information contact Melexis Direct:

Europe and Japan:

Phone: +32 13 61 16 31

E-mail: sales_europe@melexis.com

All other locations:

Phone: +1 603 223 2362

E-mail: sales_usa@melexis.com

QS9000, VDA6.1 and ISO14001 Certified