

1 Scope

The following document describes different methods of PWM (Pulse Width Modulation) control of High Brightness LEDs using MLX10803 LED Driver IC.

The applications described in this document are for driving high power LED diodes. The described circuits can be applied on other applications with similar circumstances as well, in case they fall within the specifications of the MLX10803. This is a conceptual description and in some case no component values are given. The applications described in this document have in most cases been implemented. Demonstration systems and components are available at Melexis. Please contact our nearest sales office or representative to learn more

2 General

2.1 EMR/EMC

Every kind of active current regulation generates ripple on the regulated output, this ripple can generate electromagnetic radiation (EMR) and electromagnetic coupling (EMC) to the surrounding electronic circuits. MLX10803 and the applications described in this document are designed to minimize EMR. Additional care has to be taken when designing the circuit board and the physical application. Melexis makes no claims about the suitability of any of these circuits for EMI/EMC and EMR compliance against international regulations. Compliance testing is recommended and it will fall to the user to conduct such testing prior to sale in specific countries and markets.

2.2 EMI

Very low currents are used to set the peak current sensing levels in MLX10803. It is recommended to add a capacitor in parallel to the resistors attached to IREF1 and ground and IREF2 and ground, in some cases. An alternative is to only use short wires to these inputs. MLX10803 is a very flexible circuit and uses very little energy to achieve the functions described in this application note. A person with normal electrical engineering skill should be able to decide when or if a decoupling capacitor is needed, and these capacitors will not be added in the circuit examples described in this application note.

3 Design tools

3.1 Coil calculation program in Excel™

This Microsoft Excel™ calculation sheet is necessary when designing LED driver solutions around the MLX10803.

Find this program on the Melexis web site at, <http://www.melexis.com> and search for MLX10803. Look then in the list of Assets. Download the coil_calc.xls file.

The spreadsheet is self instructive. Play with it and get a feeling about the relationship between coils, currents and sense values. The real mathematics behind the MLX10803 function is complicated, this sheet is a simplification. The tool gives only rough values, but it gives an impression what component sizes and settings are needed.

This tool will help you to find a rough value for:

- The coil
- The programmable sense voltage and the sense resistor
- The mono flop time. The time to partly discharge the coil. This time is a derivative from the oscillator frequency in MLX10803

After finding out coil, reference resistors and sense resistor values, as well as mono flop time, oscillator resistor value and sense voltage settings with this tool, it is time to apply the component values to the MLX10803 LED driver circuit and try out the values in an application.

3.2 Evaluation board EVB10803

You should make trials and tests with the evaluation board available from Melexis. This will save time and money understanding the function of the MLX10803 chip.

The LED supply can be separated from the circuit supply (VS/PWM) by removing the jumper for that on the EVB10803. See the manual for EVB10803 for instructions. When the supply to the LED is separated from the VS/PWM then the supply voltage to the LED is limited by the external N-FET transistor parameters and the fly back diode. Please use this option with great care, and check carefully what type of transistor and fly back diode your EVB10803 is equipped with before applying any higher voltage than 32V.

This option gives you the freedom to apply PWM signal on the MLX10803 supply line.

4 Applications

4.1 PWM control on the IC power supply

The most straight forward method to create a PWM modulation of the LED current is to apply the PWM signal directly to the Power supply of MLX10803. The MLX10803 circuit has a very fast power on time and there is no problem to use following circuit if the PWM signal has some of the following given properties.

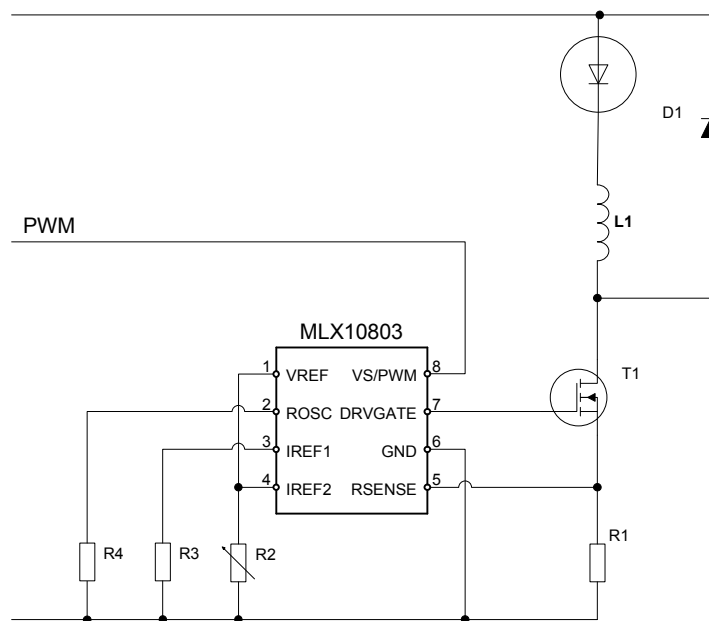

To use the schematic above, the PWM signal must be $< 0.3V$ for low (off) level and $>5V$ for high (on) level.

It is recommended is to use a PWM signal at 12V (or slightly higher). This causes the attached FET to be driven to the lowest Drain Source resistance (R_{dson}) for most common N-FETs. The DRVGATE signal is clamped to 12 V so any higher voltage on the PWM signal will only result in higher energy consumption from the attached PWM generator.

Between 5V and 12V, the attached high level voltage of the PWM signal will be the same as the gate voltage on the DRVGATE output. Note that there are N-FETs that have a lower gate voltage for fully open state but most handle also 12V on gate.

4.1.1 Supply (VS) PWM curve forms of MLX10803

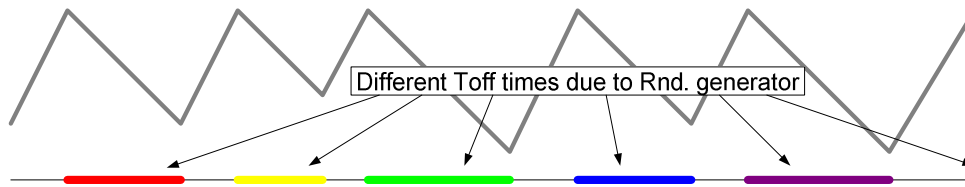

Above is an example of a normal period of regulation cycles. The curve is a direct illustration of the current through the LED. Below is illustrated the effect of PWM on the supply line of MLX10803.

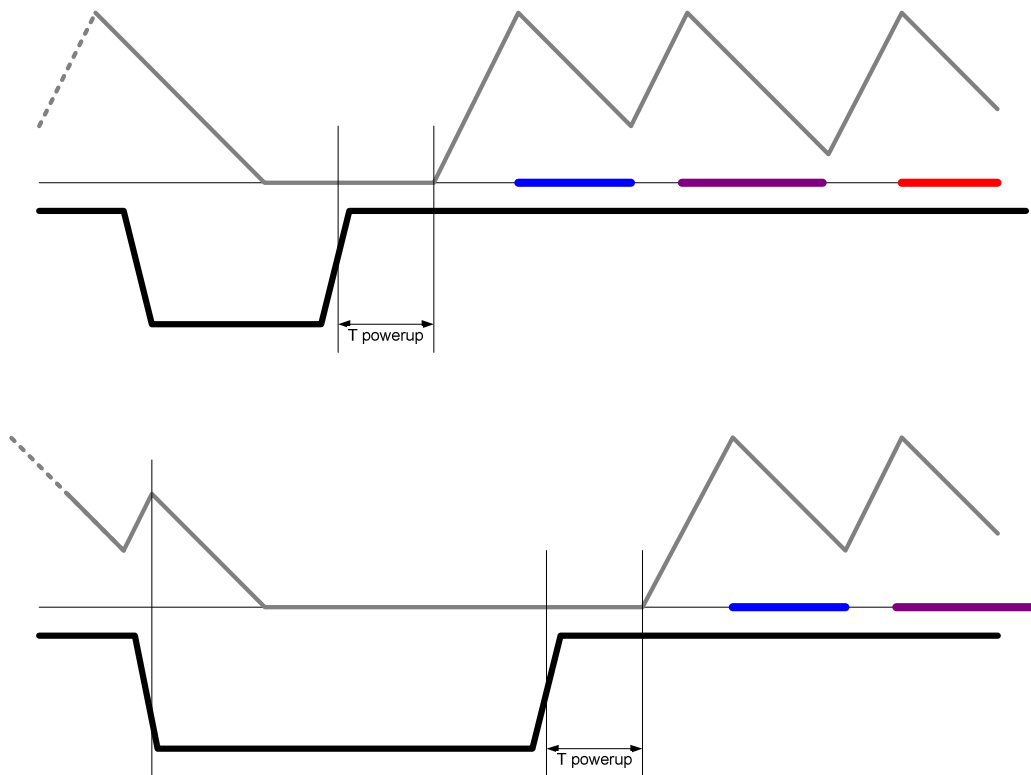

If using the VS PWM method you will have a power up time added to the PWM length at every PWM pulse. You can see an example of the waveforms above. Note also that the Circuit will start with the same sequence of discharge time length. This will reduce the positive effect of the built in randomization of the switching frequency if the PWM pulse (ON) is short.

The shortest recommended on or off periods are approximately 2 regulation cycles (or ripples). A recommended switching frequency is 50 – 150 kHz for any switching LED driver due to EMR and typical ferrite coil core types. This gives, if using 100 Hz PWM frequency, a minimal resolution of 1:250 – 1:750. Note there is no problem using higher resolution but for the highest and lowest number of PWM code the linearity will then become relatively poor.

For higher resolution a combination with different levels on VREF can improve this form of PWM.

4.2 PWM control on the VREF pin

Applying a PWM signal on the VREF pin is also very simple if the PWM voltage levels are at a suitable level. This method has also some additional interesting effects.

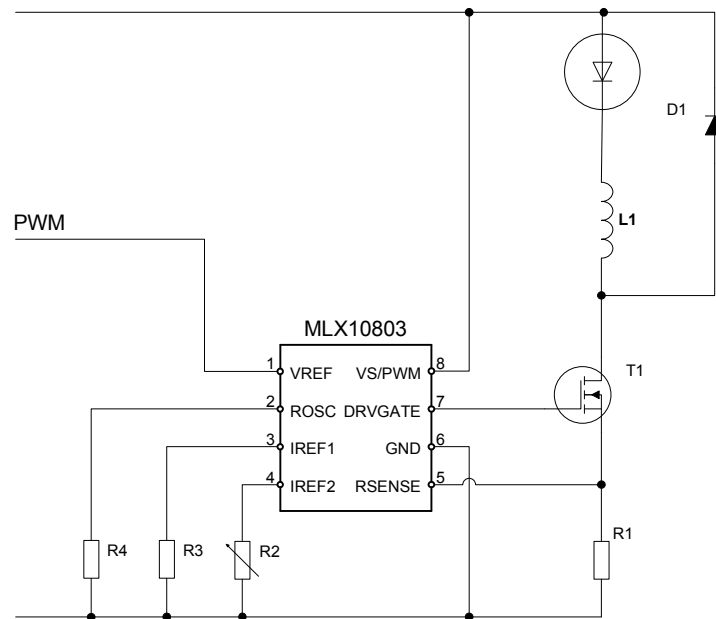

The voltage VREF pin need to be $< 0.1V$ for low (off) level and $>$ (Voltage on IREF1 or IREF2) but should not be higher then 4.5V for high (on) level. Refer to MLX10803 IC specification.

Using VREF pin as PWM input gives an interesting extra feature. The VREF is actually an analog input that gives the opportunity to low pass filter the PWM signal. This has positive effects on EMR and in addition gives the possibility for a much higher resolution of the PWM function.

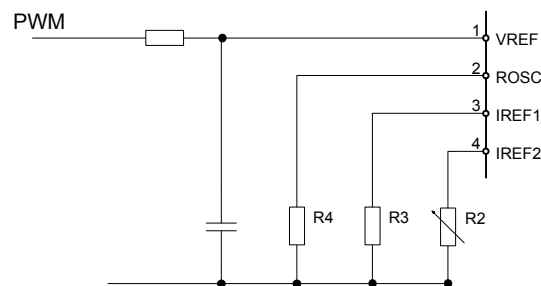

4.2.1 VREF PWM curve forms of MLX10803

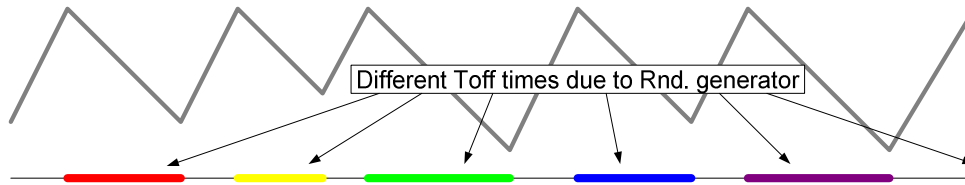

Above is an example of a normal period of regulation cycles. The curve is a direct illustration of the current through the LED. Below is illustrated the effect of PWM on the VREF of MLX10803.

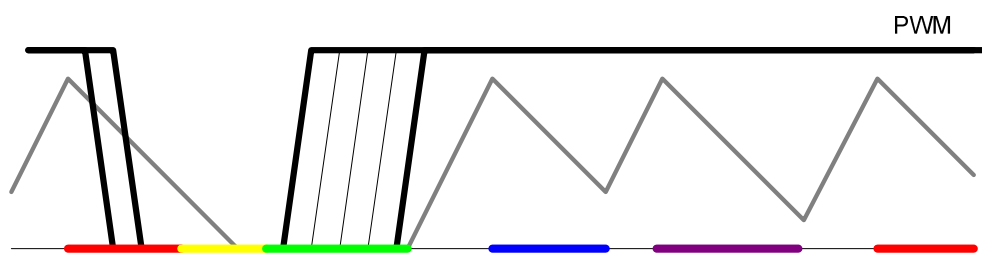

One internal behavior on MLX10803 can influence the precision using VREF PWM. There is a timer that starts when the peak value has been reached. During this timer period the circuit is insensitive to any changes on the voltage level on VREF. See the illustration above. This makes the precision of short PWM pulses bad.

A better way to work around this potential precision problem is to low pass filter the PWM signal, see illustration below. (Schematic described in Chapter 4.2)

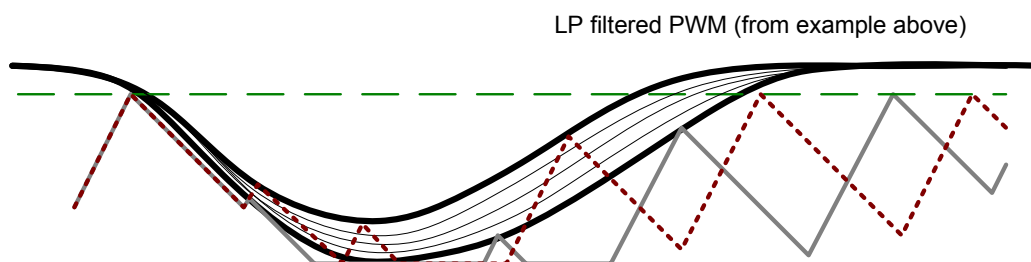

It can easily be seen out of the example above that the shorter off pulse gives a higher resulting LED current (dotted line), now when low pass filtered.

4.3 High frequency PWM

There is a method that allows for, in theory, unlimited high switching frequency and with that unlimited resolution. Well, of course, the speed on the LED sets the limit in reality. Refer to your selected LED datasheet.

4.3.1 Basic functional schematic

As seen from this schematic below, the switching is done directly in the current path of the LEDs. Actions have to be taken to handle the coil's stored energy during the period the LED is off. The simplest way to do this is to add a diode to create a current path for the coil when the transistor T2 is off. Be aware, the current must be limited with a series resistor. The current can otherwise be quite high. Note that is a very energy efficient way to do the off period, in the worst case analysis you only waste the energy over D1, D2 and the series resistor. This energy saving has a drawback though, it makes your PWM regulation a little bit nonlinear, but you can set the nonlinearity more or less freely with the series resistor. The effect will be shown in chapter 4.3.3.

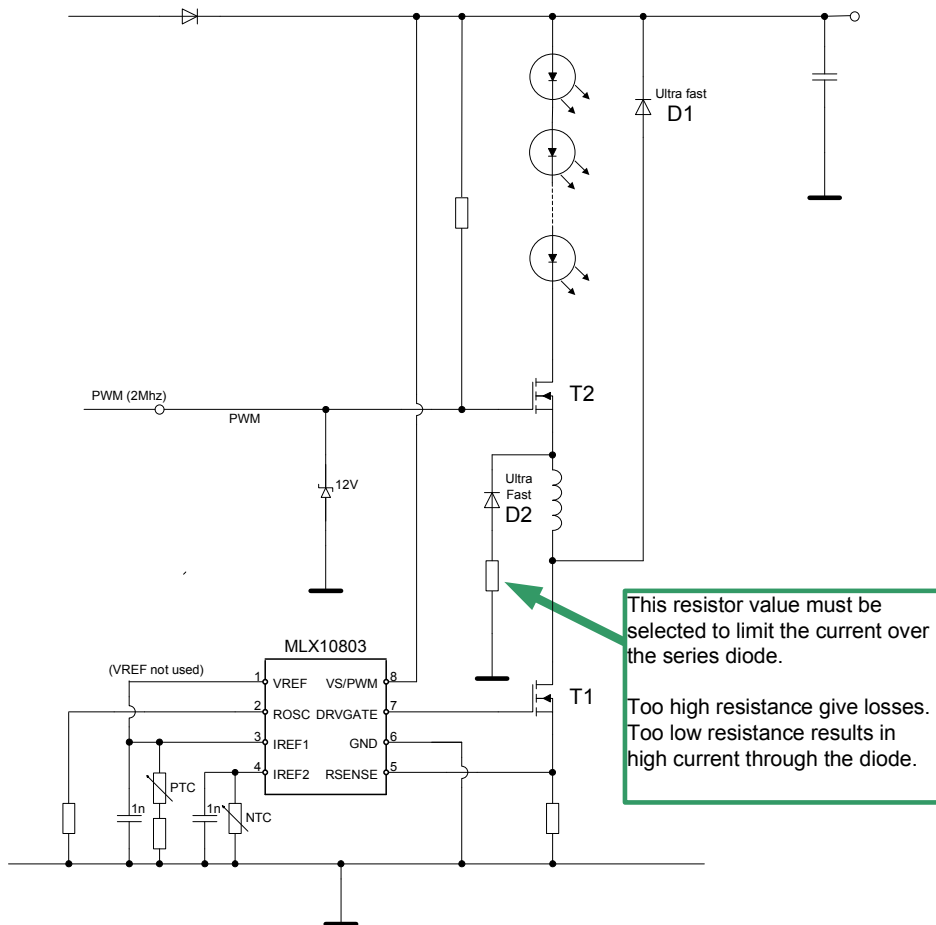

4.3.1.1 Current paths in the basic schematic

This shows the current which flows during the 4 different combinations of T1 and T2 during different PWM situations.

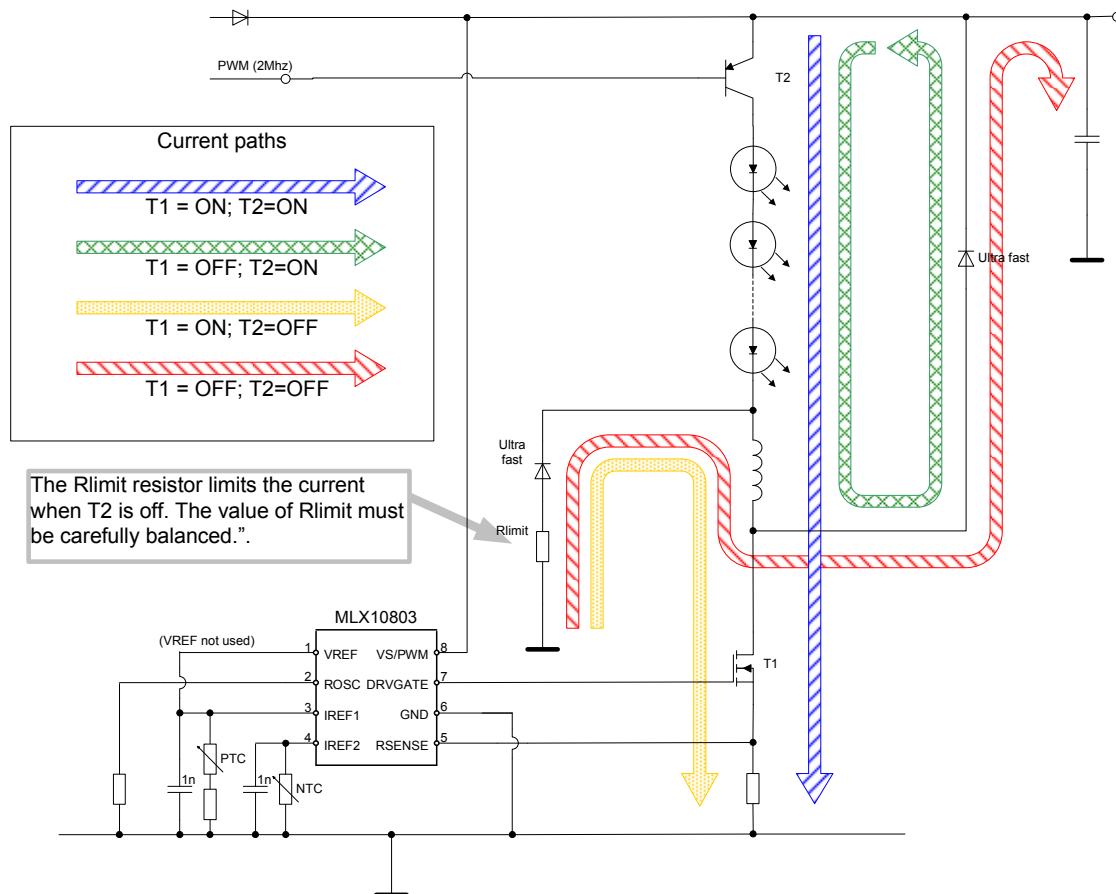

Note that when T2 is off, the charge in the coil has only the Rlimit as (resistive) current limiter. Rlimit has to be chosen so the current does not exceed the maximum value for the ultra fast diodes and the coil.

4.3.2 An alternative, using PWM and INV PWM

There is a very elegant alternative to the previous design. This design needs the overlapping inverse of the PWM signal. This application has the unique feature that PWM can be done without adding any additional noise to the LED driver. You can, of course, create steep slopes at the LED current but even that can be avoided. The design allows you to use slow rising slopes, actually even pure analogue signals can be used if the inverse signal is correct.

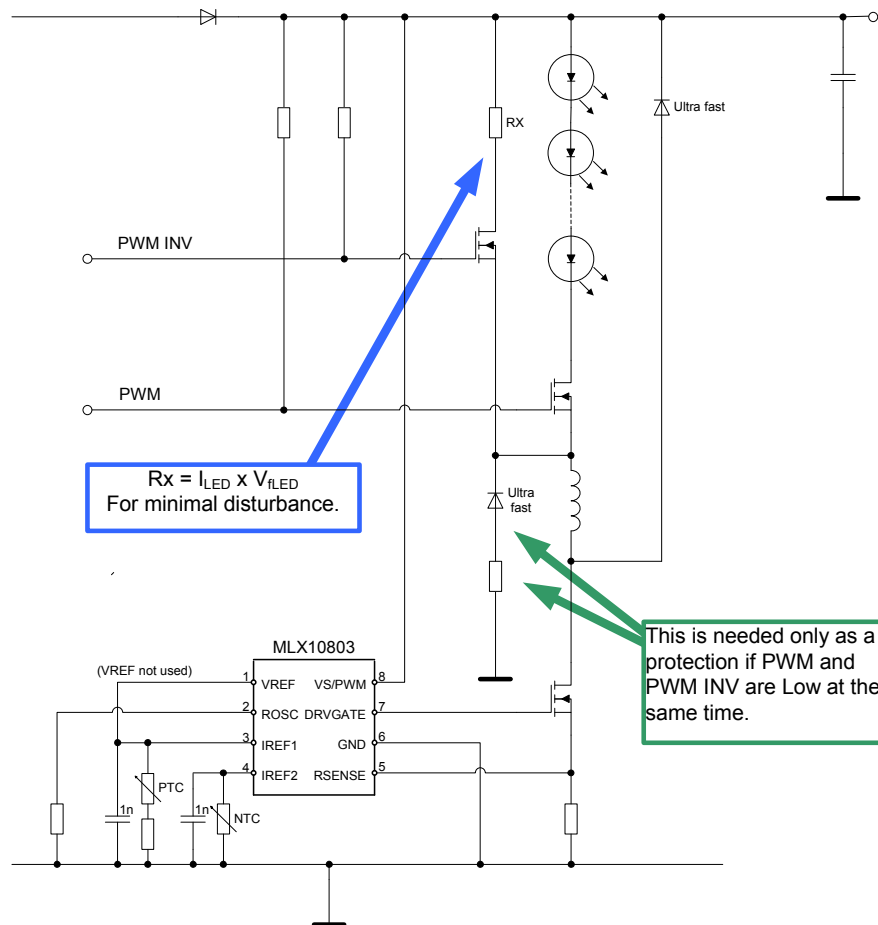

Examples of suitable PWM signal and its inverse

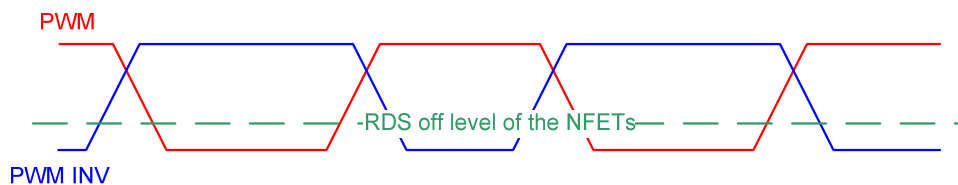

Note that both transistors are conducting in parallel during a short period in each cycle.

4.3.3 HF PWM curve forms of MLX10803

Below is the LED regulation curve forms used in the examples in subchapter 4.3.3.1 and 4.3.3.2. This large ripple is chosen to better show the kind of nonlinearity that can occur. If you want to minimize this effect, choose as small a ripple as possible and a power dissipation during the off (dark) time, that is as close to the power dissipation over the LEDs as possible.

It is also possible to compensate for this type of nonlinearities in the over all regulation of the system. Nonlinearity of the LED is probably a much larger problem. As an example, the LED shines with different intensity at different temperature.

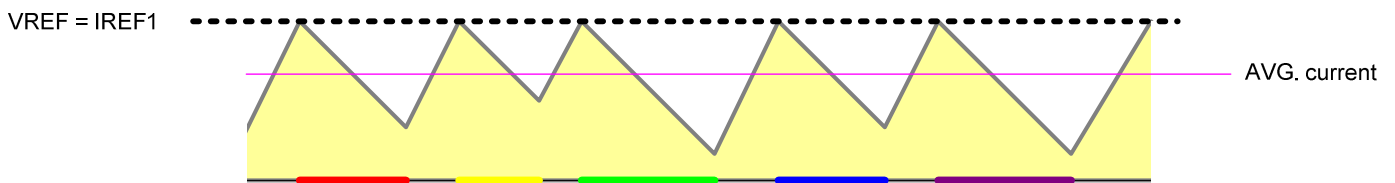

4.3.3.1 Lower than switching frequency PWM curve forms

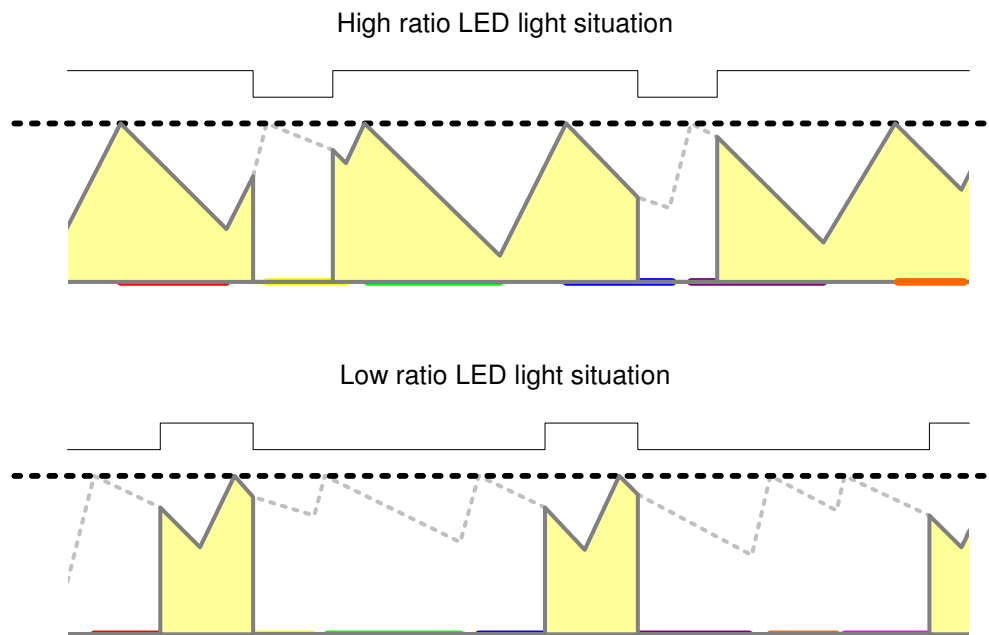

Note that the grey dotted line represents the discharge effect. This grey dotted line is directly related to the power dissipation for the alternative current path during the off period. The smaller the loss, the slower the fall of the discharge line and the faster rise of the charge line.

4.3.3.2 Higher than switching frequency PWM curve forms

High ratio LED light situation

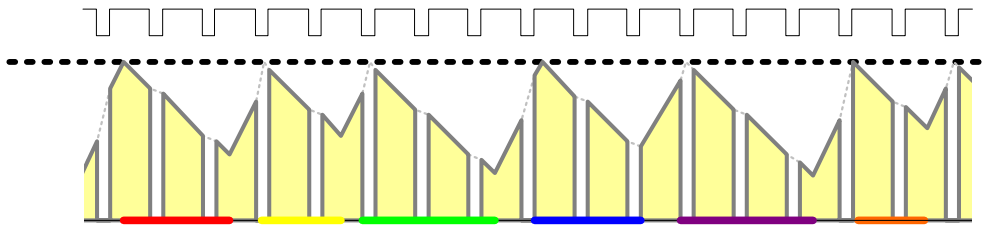

Low ratio LED light situation

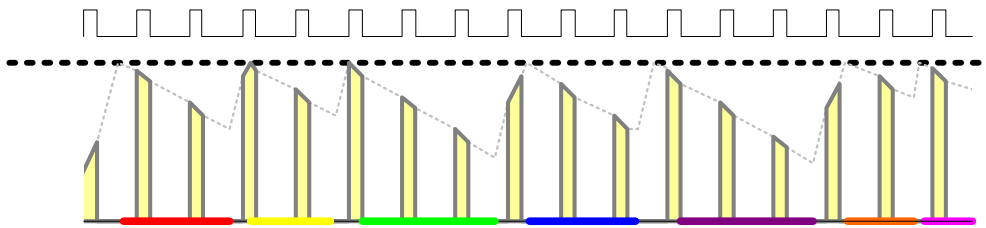

Again, note that the grey dotted line represents the discharge effect. This grey dotted line is directly related to the power dissipation for the alternative current path during the off period. The smaller the loss, the slower the fall of the discharge line and the faster the rise of the charge line.

5 Disclaimer

The circuit applications in this document have been thoroughly tested by Melexis when not otherwise mentioned; and have worked satisfactorily in the described applications. However, Melexis does not assume any legal responsibility and will not be held legally liable in the use of these circuit applications, under any circumstances.

For the latest version of this document, go to our website at:
www.melexis.com

Or for additional information contact Melexis Direct:

Europe and Japan:	All other locations:
Phone: +32 13 61 16 31	Phone: +1 603 223 2362
E-mail: sales_europe@melexis.com	E-mail: sales_usa@melexis.com

QS9000, VDA6.1 and ISO14001 Certified