

Scope

This application note provides guidelines for selecting a magnet to be used in combination with the MLX90333 Tria@is™ 3D-Joystick Position Sensor when it is desired to apply this IC as a **Linear Position Sensor**.

Related Documents, Products and Tools

The documentation and information on the products and tools listed below can be found on Melexis website www.melexis.com

Related Products

- MLX90333 Tria@is™ 3D-Joystick Position Sensor
- MLX90316 Tria@is™ Rotary Position Sensor
- MLX91204 Sine/Cosine Tria@is™ Rotary Position Sensor

Related Documents

- Application Note Linear Position Axial Parallel
- Application Note Front-End Calibration
- Application Note Back-End Calibration
- Application Note Hall Applications Guide

Related Tools

PTC04 Programmer for Melexis PTC devices

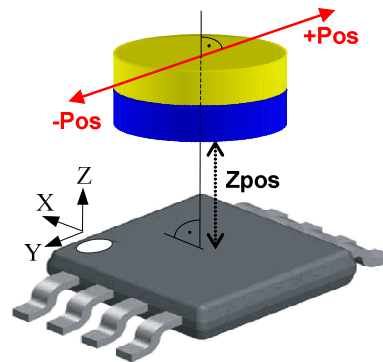

Figure 1 – MLX90333

Introduction

The MLX90333 is a monolithic sensor IC featuring the Tria@is™ Hall technology. Conventional planar Hall technology is only sensitive to the flux density applied orthogonally to the IC surface. The Tria@is™ Hall sensor is also sensitive to the flux density applied parallel to the IC surface. This is obtained through an Integrated Magneto-Concentrator (IMC®). This IMC layer is deposited on the CMOS die as a post-passivation process step but prior to encapsulation in the IC package.

The MLX90333 is sensitive to the 3 components of the flux density applied to the IC (B_x , B_y and B_z). This allows the MLX90333 to sense and measure the field of a magnet moving in its surrounding and it enables the design of innovative non-contacting linear position sensors, which are often required for both automotive and industrial applications (e. g. man-machine interface).

In combination with the appropriate signal processing, the magnetic flux density of a small magnet (axial magnetization) moving above the IC can be measured in a non-contacting way. The linear position information is computed from the three vector components of the flux density (i.e. B_x , B_y and B_z). The output formats are selectable between Analog, PWM and Serial Protocol.

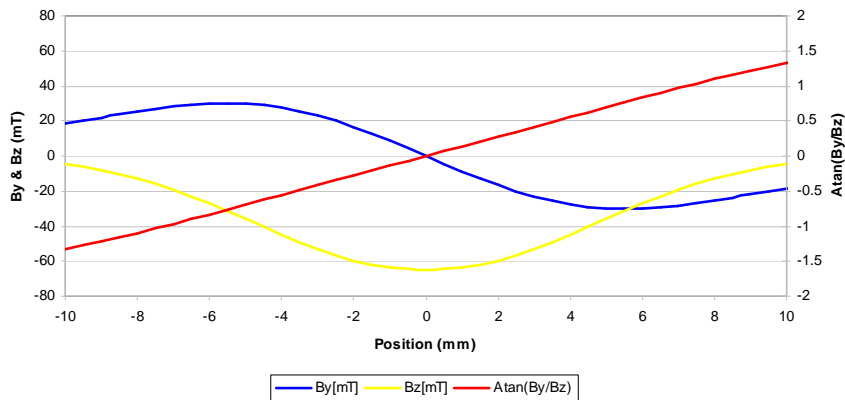

Figure 2 – B_y , B_z and the arc tangent of the ratio B_y/B_z for Figure 1

Mechanical Description

The mechanical alignment between axis of movement, magnet position and sensor position strongly determines measurement accuracy. Mechanical alignment errors (Figure 3) can result in additional offset, amplitude change and non-linearity vs. the ideal output curve.

Whereas offset and amplitude are easily trimmed and compensated at the IC level (see the Application Note on the Front-End Calibration of MLX90316), linearity errors due to mechanical tolerances (between sensor and the moving magnet) are ideally compensated through a linearization of the output transfer characteristic.

The MLX90333 allows tapping the full potential of the Tria@is™ technology. The capability of the IC in sensing flux densities in all three directions (X, Y and Z) offers different measurement ways. We present a simple and robust magnet(s)-sensor adjustment scheme.

Axially magnetized magnet with magnetization axis orthogonal to the sensor surface (Figure 3).

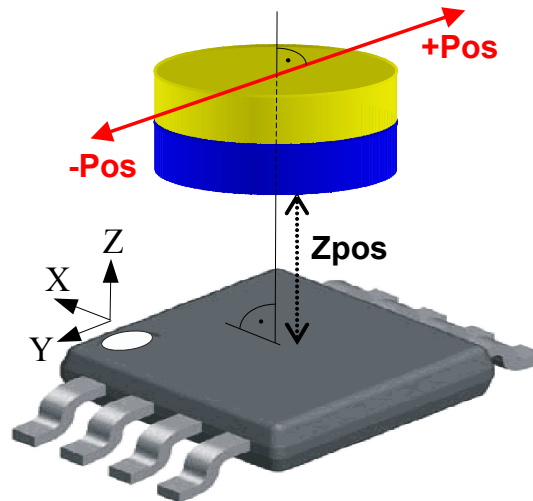

Figure 3 – Axial orthogonal magnet-sensor adjustment

The magnet is positioned above the sensor with the magnetization axis orthogonal to the IC surface. In the zero position the magnet should be placed above the magnetic center of the sensor. The movement axis should be kept parallel to the IC surface. One of the two planar components and the vertical component of the flux density are used to calculate the position of the magnet in reference to the sensor. The information is obtained through the arc tangent operation of the ratio between the chosen two components $\text{Arctan}(B_x/B_z)$ or $\text{Arctan}(B_y/B_z)$.

The working distance between magnet and sensor is defined by the saturation effects (electrical or magnetic) for the lower limit and by the required signal-to-offset or signal-to-noise ratio for the higher limit.

Note: The MLX90333 features an automatic gain control (AGC) loop to adapt to the amplitude of the available field i.e. the higher the gain, the higher the noise. The MLX91204 does not feature such an AGC loop.

Working Principle

Axial orthogonal

As a general condition, the magnetic field must be radiant to guarantee proper function and linearity. E.g. Magnet with a cylindrical shape, axially magnetized, where the measurement position is in the periphery of the magnet (Figure 4).

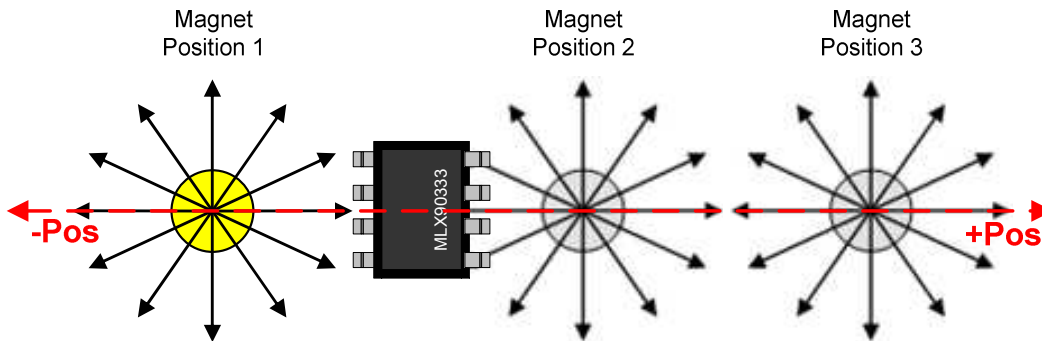

Figure 4: Sensor-Magnet adjustment (topview) axial orthogonal

This allows to measure the direction of the magnetic field by a three axis sensor with the components B_x (or B_y) and B_z (Figure 5) and therefore determine the geometrical position of either sensor or magnet.

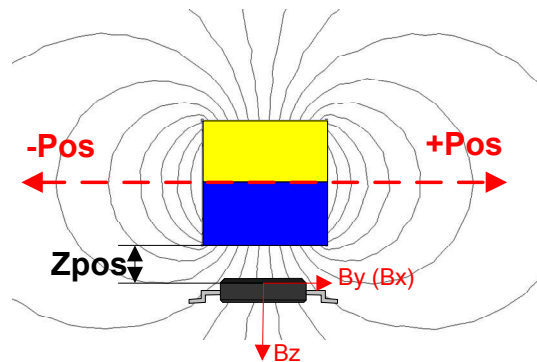

Figure 5: Measured field components B_z and $B_x(B_y)$ (sideview) axial orthogonal

For a travel along the X-axis the position is determined as:

$$X_{Pos} = m \cdot \arctan\left(\frac{B_y}{B_z}\right)$$

with m : slope of the output transfer curve

The linear position information can also be obtained through the arc tangent function of B_x/B_z .

Extend the Range with Multiple Magnets

This section shows the magnet-sensor adjustment of more than one magnet. If bigger linear strokes are required, the combination of two or three magnets allows increasing the usable linear range.

The same working principle as for a single magnet is used. The main difference is that additional magnets are used to keep the flux density in the desired range. Various arrangements of the magnets are possible, the illustrated example (Figure 6) has been evaluated for the **axial orthogonal** arrangement and the results obtained are excellent.

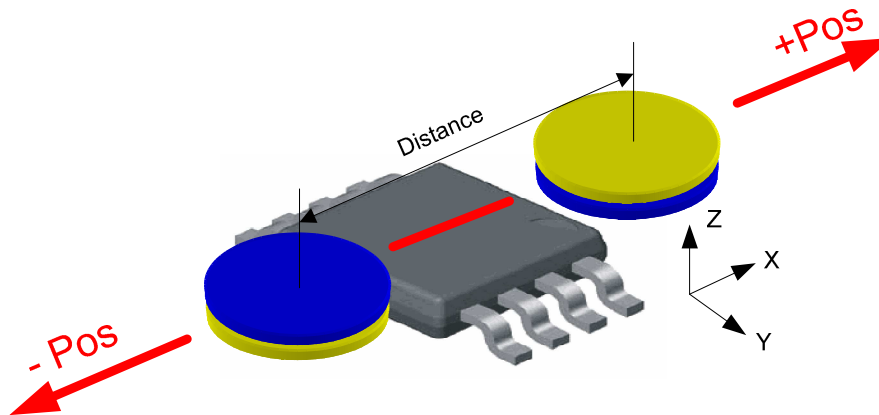

Figure 6: Magnets-sensor arrangement with two magnets axial orthogonal

It is important that the magnets are arranged anti polar to each other. The exact mechanical adjustment is strongly dependent on the used magnets and on the desired measurement range. The sensor perceives the flux densities generated by the two magnets; Figure 7 shows the side view of the sensor-magnets system. With a movement of the sensor the direction and strength of the flux density is changing.

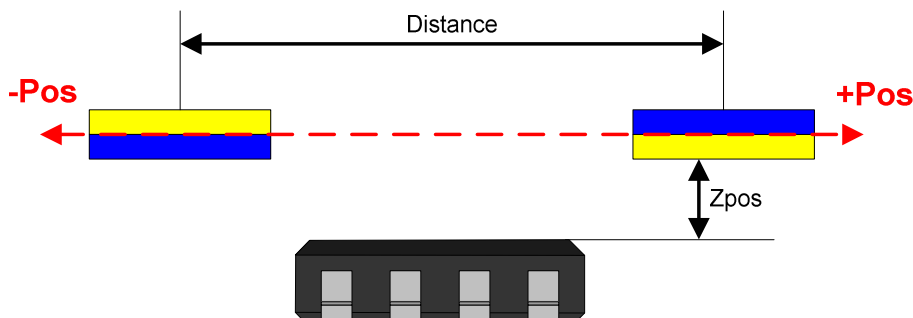

Figure 7: Magnets-sensor arrangement with two magnets axial orthogonal (side view)

A further extension of the usable linear range is possible using three magnets adjusted anti parallel to each other.

Application Table Magnets for MLX90333 Linear Position Sensor

Some typical magnets used in this application note:

Axial orthogonal adjustment with one, two and three magnets

| Magnet(s) (Cylinder, axially magnetized) | Size (D; H) [mm] | Stroke [mm] | Z Position [mm] | Distance (magnet- magnet) [mm] | Material* (Temperature -40°C...+150°C) |
|--|------------------------|----------------------|-----------------------|---|---|
|  | 1x D6 H3 2x D6 H3 | 12 (±6) 28 (±14) | 3.5 | 1 x 14 | SmCo, NdFeB Br=900...1450mT |
|  | 1x D10 H4 2x D10 H4 | 20 (±10) 44 (±22) | 6 | 1 x 26 | SmCo, NdFeB Br=900...1450mT |
|  | 1x D18 H6 2x D18 H6 | 30 (±15) 60 (±30) | 10.5 | 1 x 35 | SmCo, NdFeB Br=900...1450mT |

Table 1: Application Table for Linear Position with MLX90333

*: SmCo and NdFeB are used as an example, but all magnet materials can be used, as long as a flux density between 20 and 70 mT is guaranteed. The dimension of the magnet increases with decreasing magnet material strength.

Simulations

Stroke 12 mm (± 6)

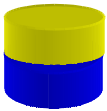
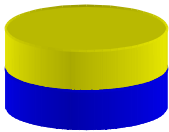
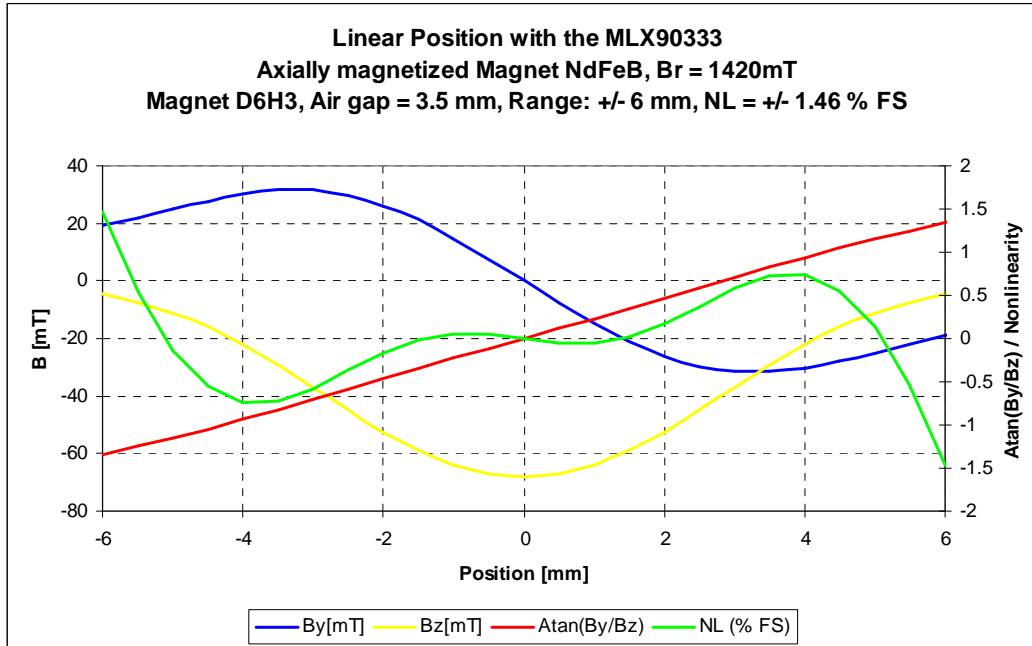

Figure 8: Simulated By, Bz and Atan(By/Bz) magnet D6H3

Stroke 20 mm (± 10)

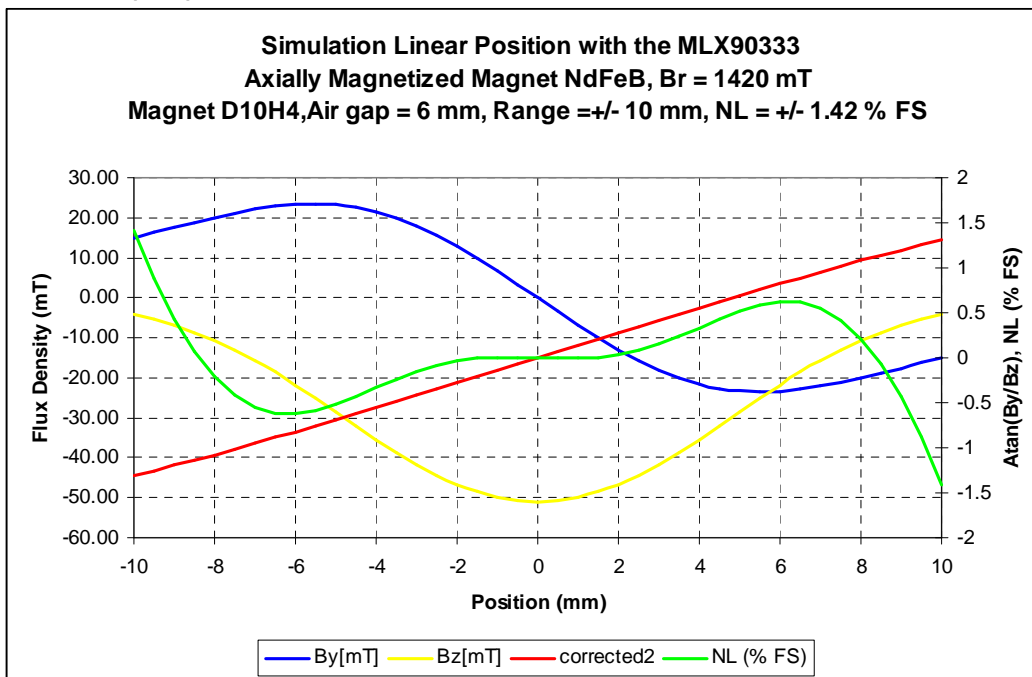

Figure 9: Simulated By, Bz and Atan(By/Bz) magnet D10H5

Stroke 30 mm (± 15)

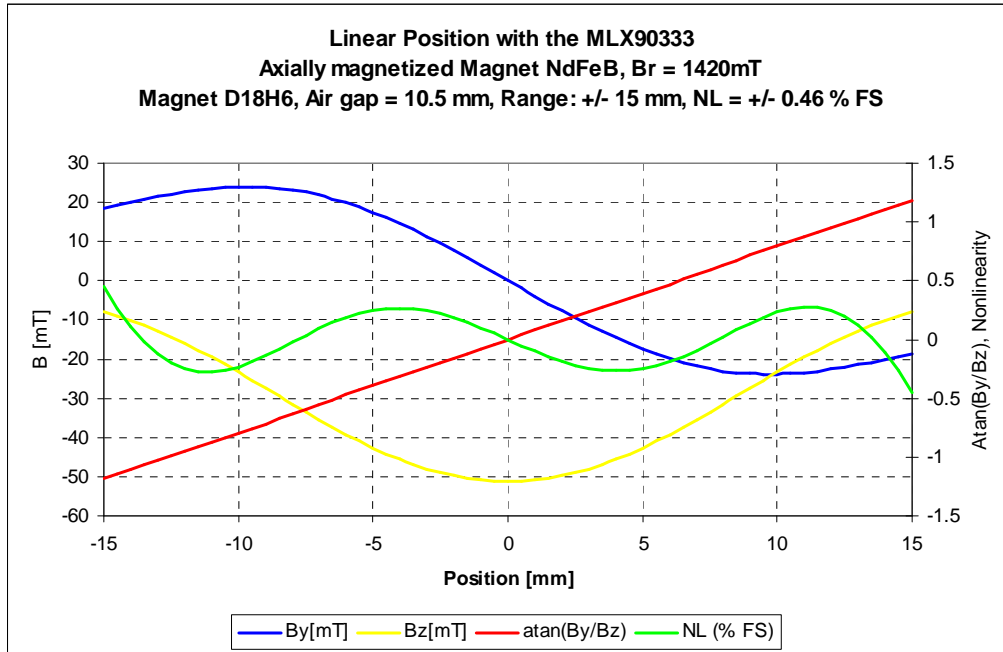

Figure 10: Simulated B_y , B_z and $\text{Atan}(B_y/B_z)$ magnet D15H5

Measurements

The measurement results show that the obtained values are better than the theoretically obtainable values due to the calibration capability of the MLX90333. The following measurements are done with a 5-Points end of line calibration of the output transfer characteristic.

Stroke 12 mm (± 6)

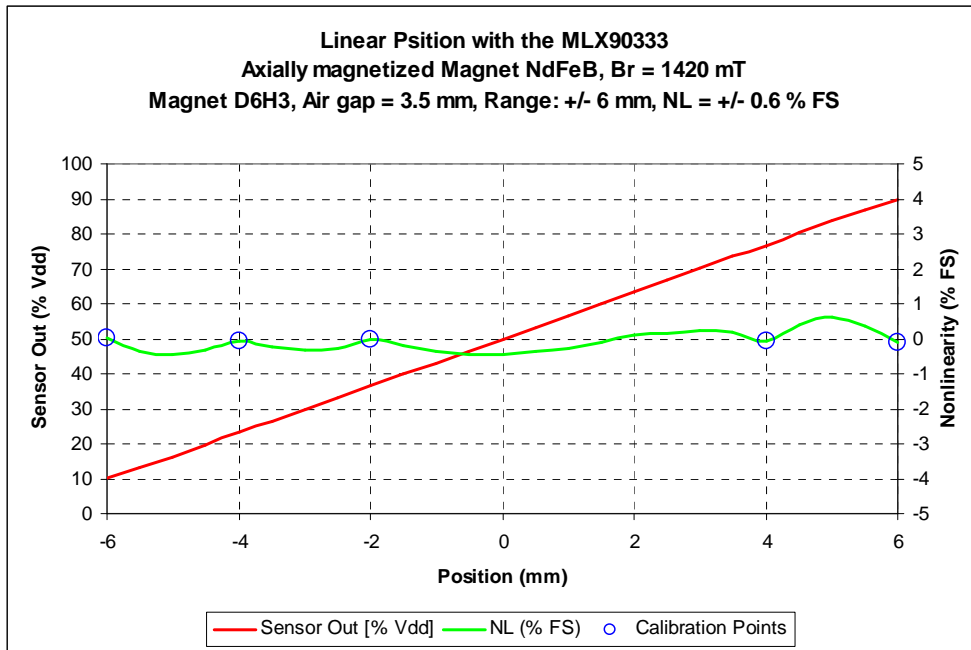

Figure 11: Measurement with MLX90333 and magnet D6H3

Stroke 20 mm (± 10)

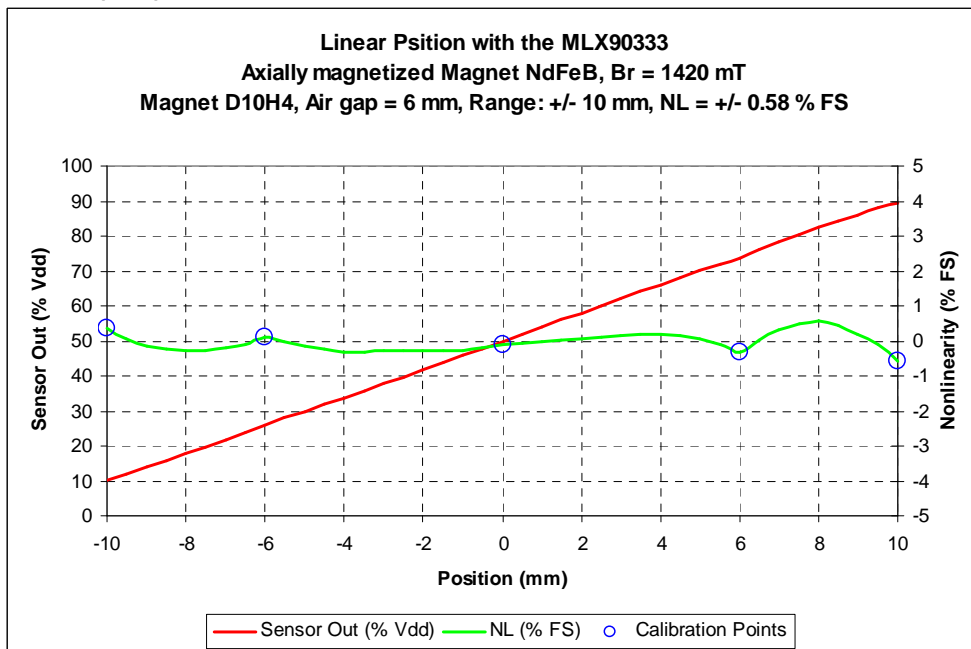

Figure 12: Measurement with MLX90333 and magnet D10H4

Stroke 30 mm (± 15)

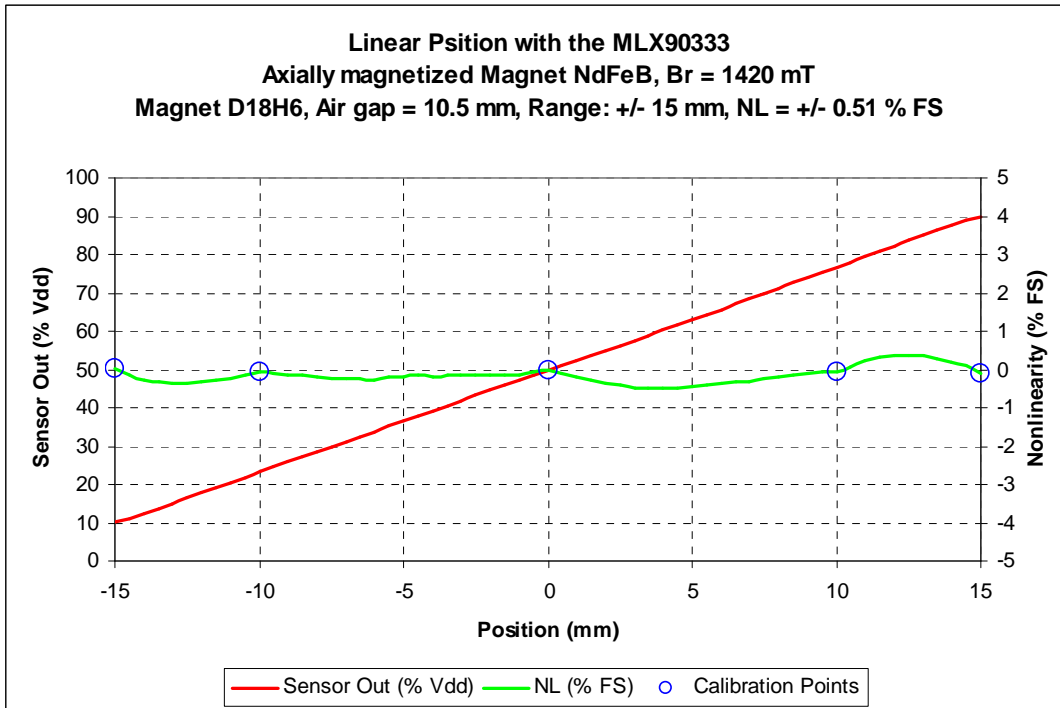

Figure 13: Measurement with MLX90333 and magnet D18H6

Accuracy

To minimize errors due to assembly or lifetime wear-out, the Z position of the sensor should be chosen as big as possible, or the placement should be more accurate. Table 2 shows the maximum calculated position errors for a variation of the air gap between sensor and magnet (Figure 14) for the magnets used in this Application Note. The theoretical possible error amount is confirmed with measurements as shown in the measured values column in Table 2.

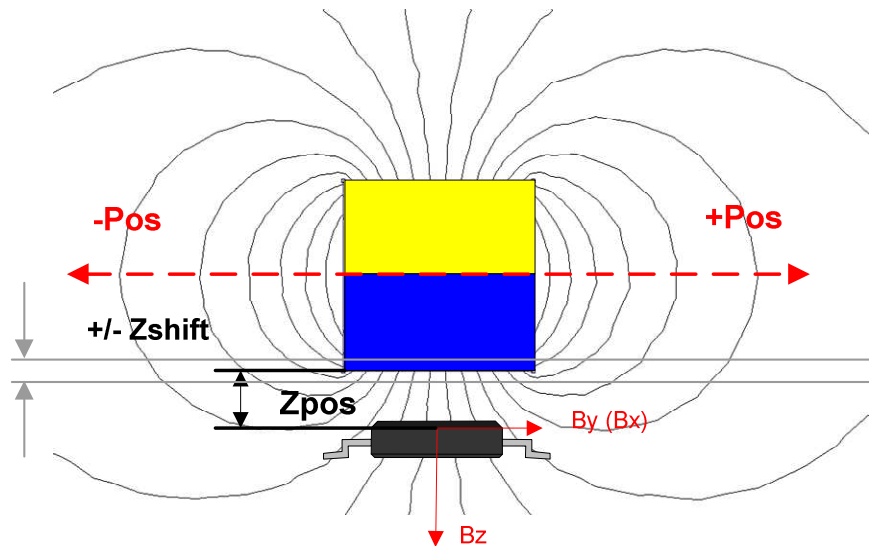

Figure 14: Variation of the air gap between magnet and sensor

| Magnet(s) (Cylinder, axially magnetized) | Size (D; H) [mm] | Stroke [mm] | Calculated Error [% FS] Zoffset ±0.1mm (±0.5 mm) | Measured Error [% FS] Zoffset ±0.1mm (±0.5 mm) | Nominal Z-Position [mm] |
|---|---------------------|----------------|--|--|----------------------------|
|  | D6 H3 | 12 (±6) | ±0.65 (±3.4) | ±0.7 (±3.5) | 3.5 |
|  | D10 H4 | 20 (±10) | ±0.38 (±1.96) | ±0.45 (±2.1) | 6 |
|  | D18 H6 | 30 (±15) | ± 0.23(±1.18) | ± 0.22(±1.1) | 10.5 |

Table 2: Errors due to a variation of the Z position

**Simulated and Measured Error due to Zshift of +/- 0.1 and +/-0.5 mm
Magnet Size D6H3, Stroke 12 (+/- 6) mm, Nominal Zpos 3.5 mm**

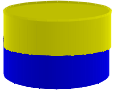
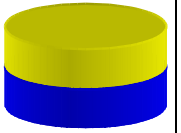
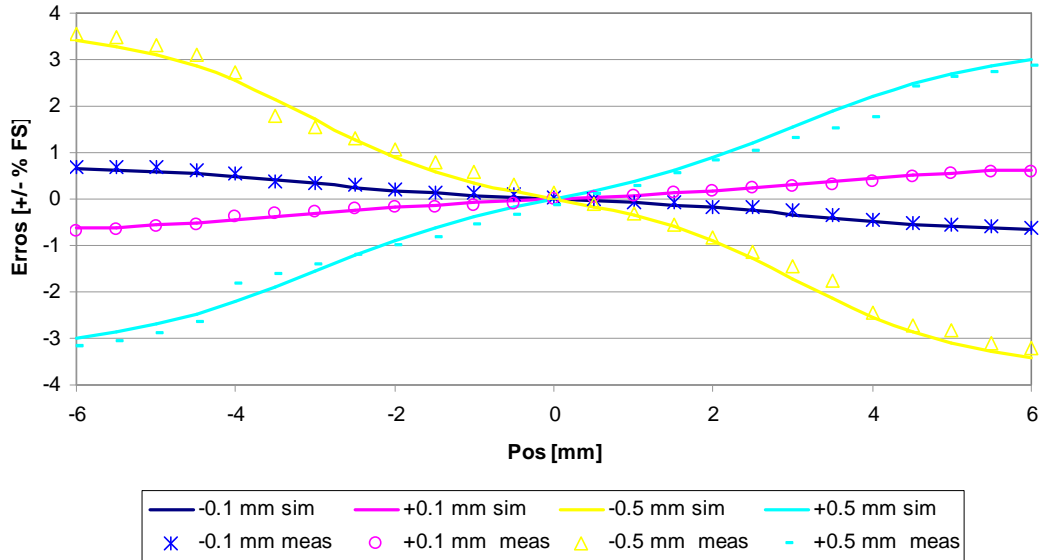

Figure 15: Calculated and Measured Error due to a change of Z position, Magnet D6H3

**Simulated and Measured Error due to Zshift of +/- 0.1 and +/-0.5 mm
Magnet Size D10H4, Stroke 20 (+/- 10) mm, Nominal Zpos 6.0 mm**

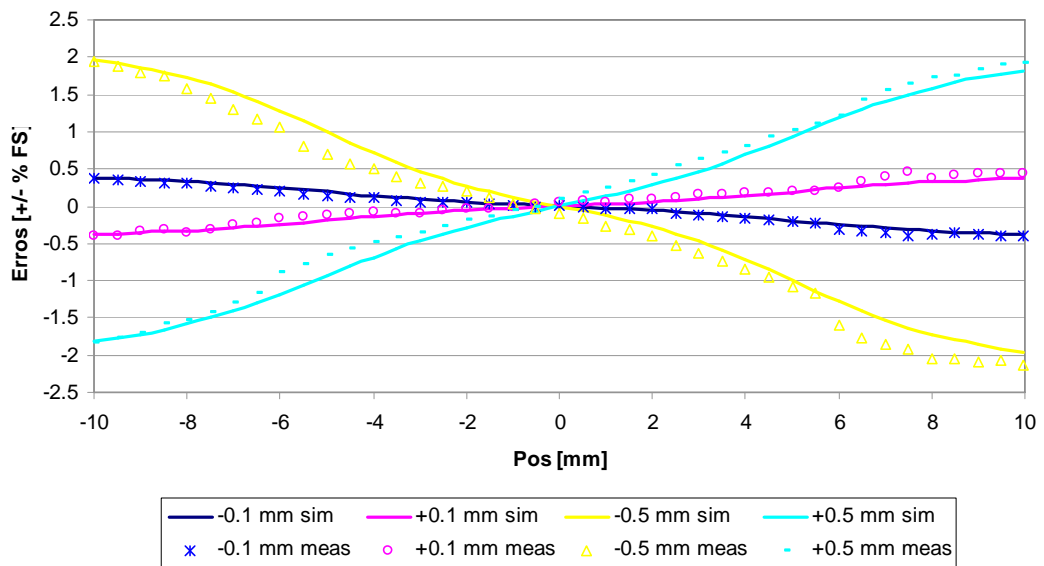

Figure 16: Calculated and Measured Error due to a change of Z position, Magnet D10H4

**Simulated and Measured Error due to Zshift of +/- 0.1 and +/-0.5 mm
Magnet Size D18H6, Stroke 30 (+/- 15) mm, Nominal Zpos 10.5 mm**

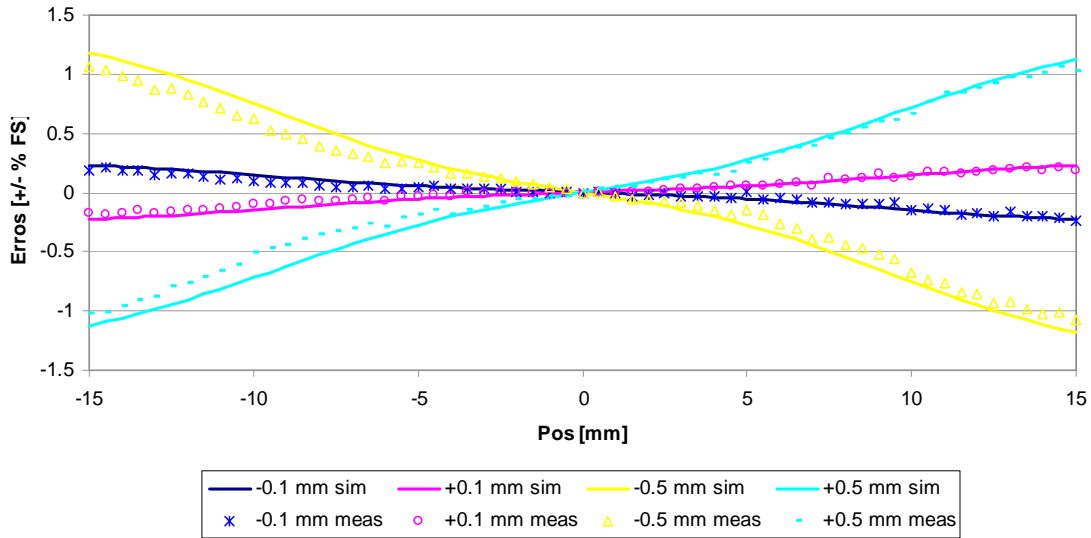

Figure 17: Calculated and Measured Error due to a change of Z position, Magnet D18H6

Material properties (Please refer to your suppliers material documentation)

| Material | | Strength Br [mT] | Drift [%/°C] | Advantages |
|--------------|-----------------|------------------|--------------|---|
| NdFeB | Neodymium | 1300 | -0.07 | <ul style="list-style-type: none"> Best magnetic characteristic |
| SmCo | Samarium-Cobalt | 1000 | -0.03 | <ul style="list-style-type: none"> Best magnetic characteristic over a wide temperature range |
| HF | Hard Ferrite | 300 | -0.2 | <ul style="list-style-type: none"> Economical material |
| Bonded NdFeB | Plastic Bonded | 450 | -0.1 | <ul style="list-style-type: none"> all magnet shapes are readily fabricated good magnetic characteristic Economical material |

Table 3: Magnet Material Properties

Aging: Has to be specified by your supplier.

Magnet Producers (Melexis does not take any responsibility for the magnet quality of the herein listed suppliers their names are provided for reference)

| Company | website | phone | types of magnet |
|--|---|----------------------|---|
| Magnetfabrik Bonn D - 53119 Bonn | www.magnetfabrik.de | +49 (0) 228 72905-13 | HF / SmCo / NdFeB / Plastic Bonded |
| Magnetfabrik Schramberg D-78713 Schramberg-Sulgen | www.magnete.de | +49 (0) 7422 519-226 | HF / SmCo / NdFeB / Plastic Bonded |
| Maurer Magnetic CH-8627 Grüningen | www.maurermagnetic.ch | +41 (0)44 936 60 30 | HF / SmCo / NdFeB / Plastic Bonded |
| BBA CH-5001 Aarau | www.bba.ch | +41 (0)62 836 90 56 | HF / SmCo / NdFeB / Plastic Bonded |
| Precision magnetic CH-5242 Lupfig | www.precisionmagnetics.com | +41 (0)56 464 21 23 | HF / SmCo / NdFeB / Plastic Bonded |
| Bomatec CH-8181 Höri | www.bomatec.ch | +41 (0)1 872 10 00 | HF / SmCo / NdFeB / Plastic Bonded / AlNiCo |
| SURA MAGNETS AB 614 31 Söderköping | www.suramagnets.se | +46 (0) 121 353 10 | HF / SmCo / NdFeB / Plastic Bonded / AlNiCo |
| Energy Conversion Systems Cary, NC 27511 | http://www.ecs-global.net/p_magnets.html | 001 910 892-8081 | HF / SmCo / NdFeB / Plastic Bonded / AlNiCo |
| Magnet Applications Ltd Berkhamsted UK | www.magnetapplications.com | +44 (0) 1442 875 081 | HF / SmCo / NdFeB / Plastic Bonded / Alnico |

Table 4: Magnet Producers