

Melexis Development Kit

MLX91209

Rev 002 – 25/09/20

1. Description

The development kit provides the needed information and components to develop a current sensor based on the MLX91209. The main goal is to show the functionalities and the features of the part in a simple and effective way.

The kit includes:

- 5 samples MLX91209-CA;
- 3 separated bare PCBs;
- 3 ferromagnetic cores (Supra 50 SP);

Datasheet and Application Note can be found on www.melexis.com

2. MLX91209 EVB1 Layout

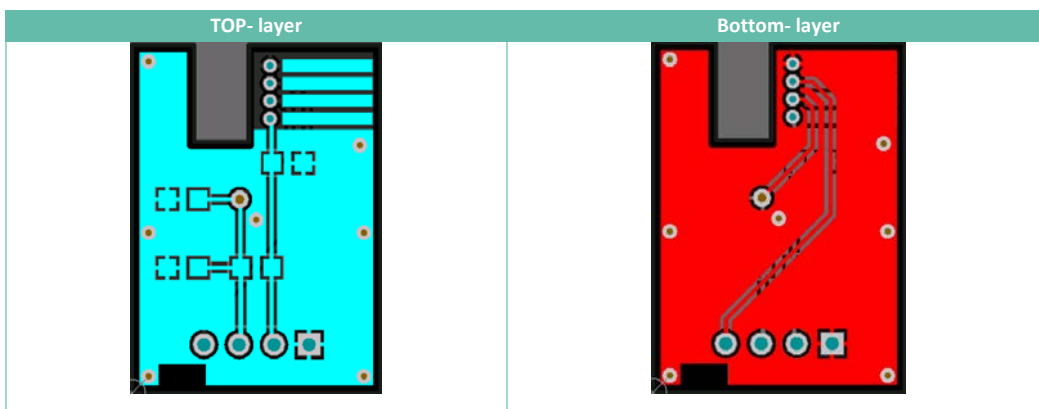

3. Sensor sensitivity

MLX91209-VA current sensors are factory calibrated to a default sensitivity of **50 mV/mT**. MLX91209 is fully programmable at customer level within a range 5-150 mV/mT. The “positive” direction field is from the bottom to the top of the package (see drawing below).

Product Code	Sensitivity Range (Typ.)
MLX91209 CA	5-150 mV/mT (50mV/mT)

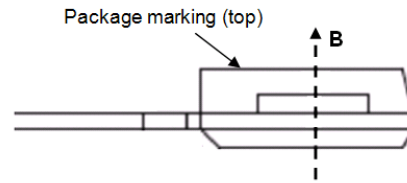

4. Sensor pin-out and connections

Diagnostic low

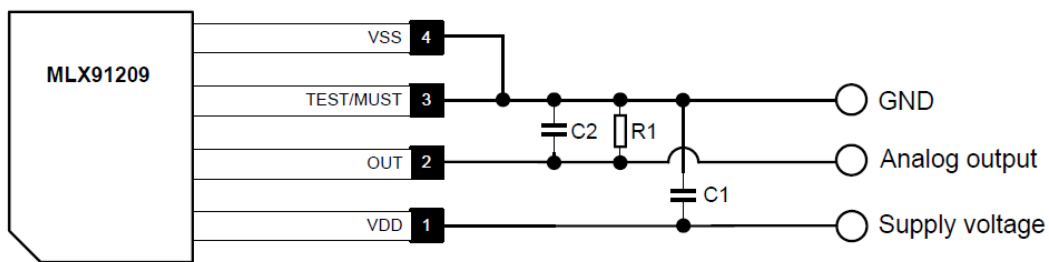

Diagnostic high

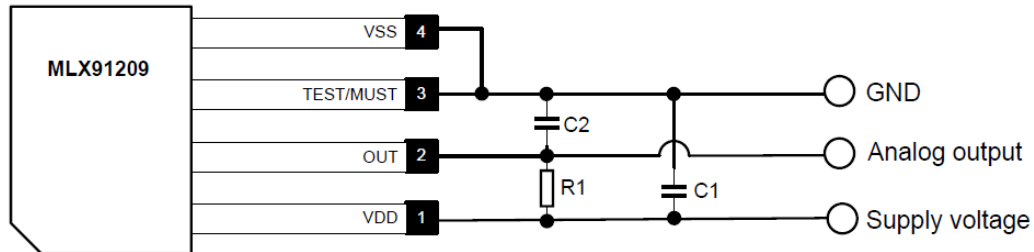

Figure 1: Connections schematics for MLX91209

Pin #	Name	Type	Function
1	VDD	Supply	Supply Voltage
2	OUT	Analog	Current Sensor Output
3	TEST/MUST	Digital	Test and Factory Calibration
4	VSS	Ground	Supply Voltage

Table 1: Pin out description

(1) 10nF is recommended for better EMC and ESD performance

Part	Description	Value	Unit
C1	Supply capacitor, EMI, ESD	100	nF
C2	Decoupling, EMI, ESD	2-10 ⁽¹⁾	nF
R1	Pull up or pull down capacitance	6-100	kΩ

Table 2: Capacitors typical values

5. Ferromagnetic cores specifications

5.1. Material properties

- Supra 50 (NiFe 50%)
- Permeability = 100000
- Saturation flux density $B_s > 1T$
- Hysteresis = 2.8 A/m
- Curie temperature: 450 deg C

5.2. Geometry

All dimensions are in mm. Airgap is **5 mm**.

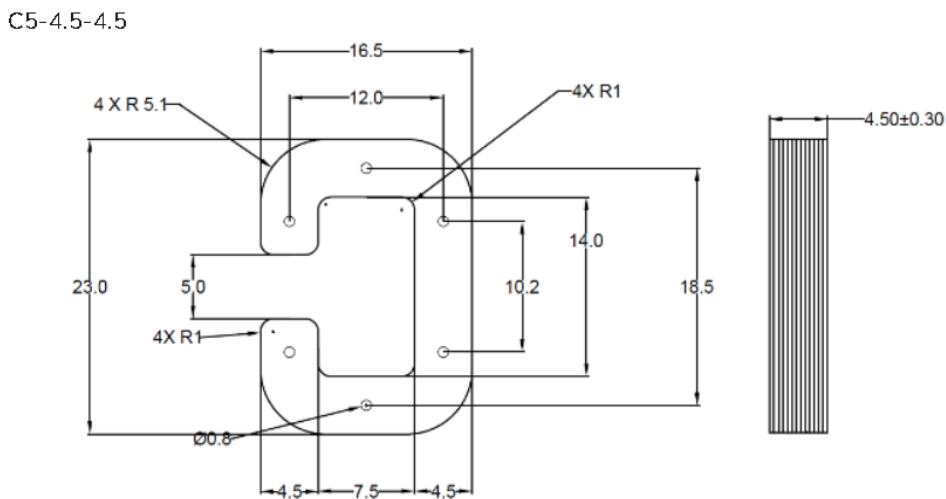

5.3. Ferromagnetic core supplier

Melexis partnered with MagLab and PML India for ferromagnetic material supply.



www.maglab.ch



www.pmlindia.com

Recently, PML and maglab signed an exclusive collaboration in the field of contactless current sensing. This cooperation between maglab and PML offers an efficient and cost-effective solution for customers requiring magnetic cores. Maglab takes care of the engineering side, while PML manufactures the products to our specifications.

6. Typical output

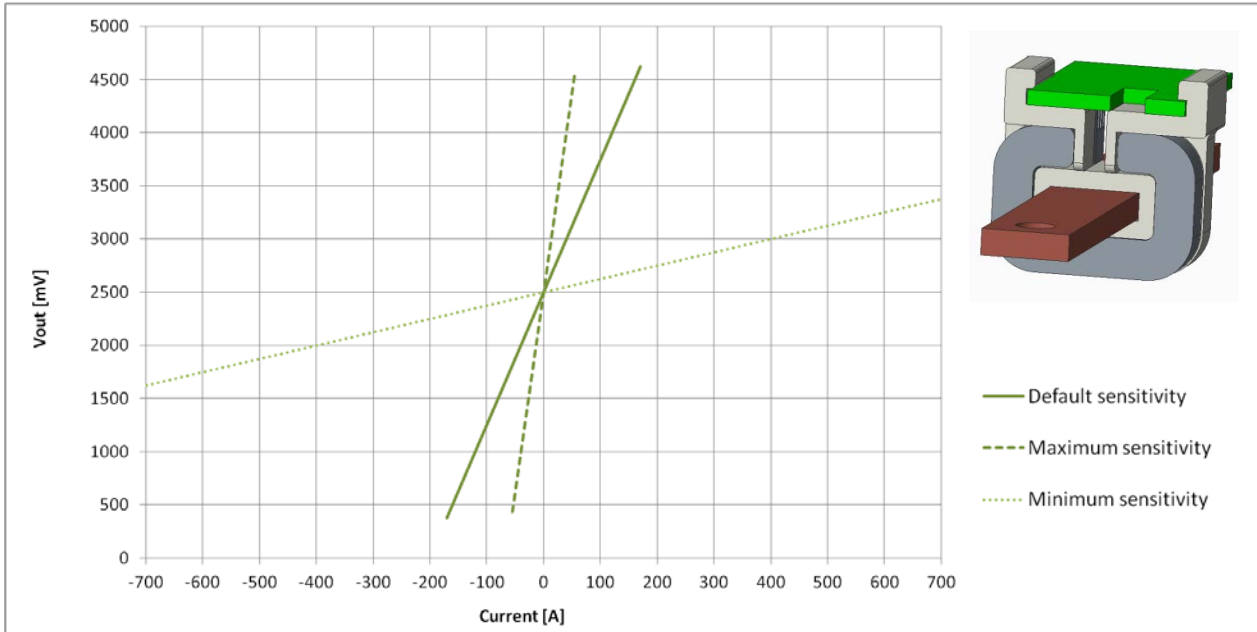

	Core air gap (5 mm)			
	91209CA default sensitivity 50 mV/mT	91209CA calibrated with max sensitivity 150 mV/mT	91209CA calibrated with min sensitivity 5 mV/mT	91209CA Typical inverter application 10 mV/mT
Sensitivity [mV/A]:	13	40	1.25	2.5
Current range [A]:	+/- 160	+/- 50	+/- 1600*	+/- 800

* The 5 mm magnetic core starts to saturate at 700A => use larger airgap for higher currents.